

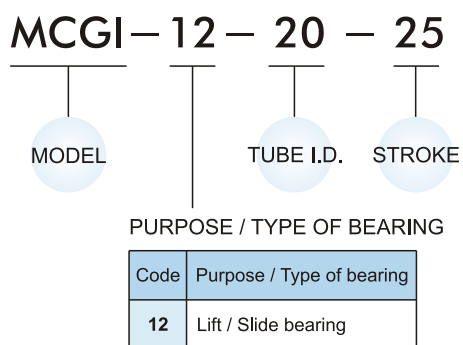

Table for standard stroke

Tube I.D.	Stroke (mm)
φ 20,25	5, 10, 15, 20, 25, 30, 40, 50, 60, 80, 100
φ 32,40	5, 10, 15, 20, 25, 30, 40, 50, 60, 80, 100, 200
φ 50,63,80	10, 15, 20, 25, 30, 40, 50, 60, 80, 100, 200, 300

※ Please consult us if stroke out of specification.

Order example



Features

- Higher loading capacity compared to unguided standard compact cylinders.
- Wide range of bore sizes and strokes.
- Ultra compact, light weight and space saving.
- Sensor slots on RCI sides for flush mounting of proximity sensors.
- Magnetic as standard.

Specification

Model	MCGI	
Acting type	Double acting	
Tube I.D.(mm)	20, 25	32, 40, 50, 63, 80
Port size	M5 × 0.8	G1/8
Medium	Air	
Operating pressure range	0.15~1 MPa	0.1~1 MPa
Proof pressure	1.5 MPa	
Cushion	Rubber bumper	
Available speed range	50~500 mm/sec	
Lubricator	Without lubrication	
Stroke length tolerance (※ 1)	+ 0~+ 1.0 mm	
Ambient temperature	- 5°C ~ + 60°C (No freezing)	
Sensor switch (※ 2)	RCI	

※ 1. Stroke length tolerance does not include the amount of bumper change.

※ 2. RCI specification, please refer to page V-10.

Mounting accessories

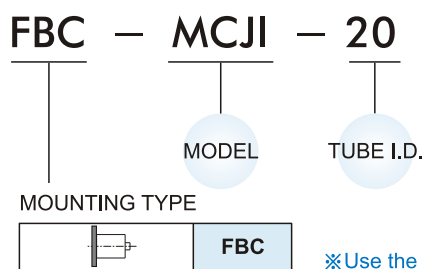

Installation of sensor switch

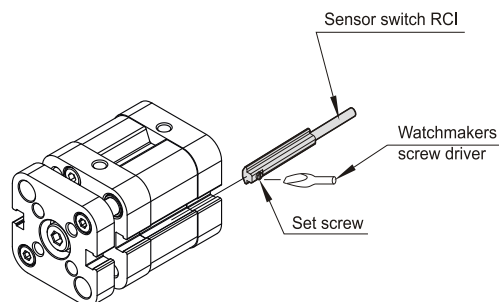

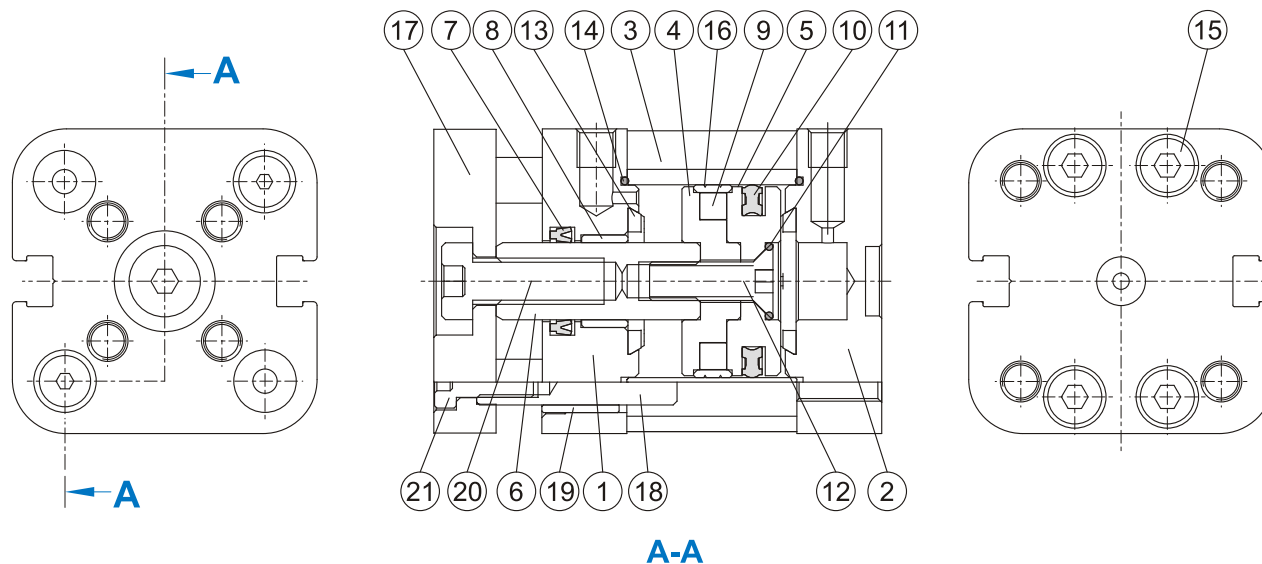

Material

No.	Part name	Material	Q'y	Component parts (inclusion)	Repair kits (inclusion)
1	Rod cover	Aluminum alloy	1	●	
2	End cover	Aluminum alloy	1	●	
3	Tube	Aluminum alloy	1		
4	Piston-R	Aluminum alloy	1	●	
5	Piston-H	Aluminum alloy	1	●	
6	Piston rod	Medium carbon steel	1		
7	Rod packing	NBR	1	●	●
8	Bush	Bearing alloy	1	●	
9	Magnet ring	Magnet material	1	●	
10	Piston packing	NBR	1	●	●
11	O-ring	NBR	1	●	●
12	Screw	Carbon steel	1	●	
13	Cushion	NBR	2	●	●
14	O-ring	NBR	2	●	●
15	Screw	Stainless steel	6	●	
16	Wear ring	Teflon	1	●	
17	Plate	Aluminum alloy	1	●	
18	Guide rod	Medium carbon steel	2		
19	Guide rod bush	Bearing alloy	2	●	
20	Bolt for piston rod	Carbon steel	1	●	
21	Bolt for guide rod	Carbon steel	2	●	

Order example of component parts / repair kits

Tube I.D.	Component parts	Repair kits
φ 20	CP-MCGI-20	PS-MCJI-20
φ 25	CP-MCGI-25	PS-MCJI-25
φ 32	CP-MCGI-32	PS-MCJI-32
φ 40	CP-MCGI-40	PS-MCJI-40
φ 50	CP-MCGI-50	PS-MCJI-50
φ 63	CP-MCGI-63	PS-MCJI-63
φ 80	CP-MCGI-80	PS-MCJI-80

※Use the same repair kits with MCJI.

Cylinder weight

unit:g

Model	Basic weight MCGI-11	Stroke 10 mm MCGI-11
Tube I.D.		
φ 20	146	18
φ 25	172	22
φ 32	280	28
φ 40	378	40
φ 50	614	58
φ 63	871	60
φ 80	1,564	94

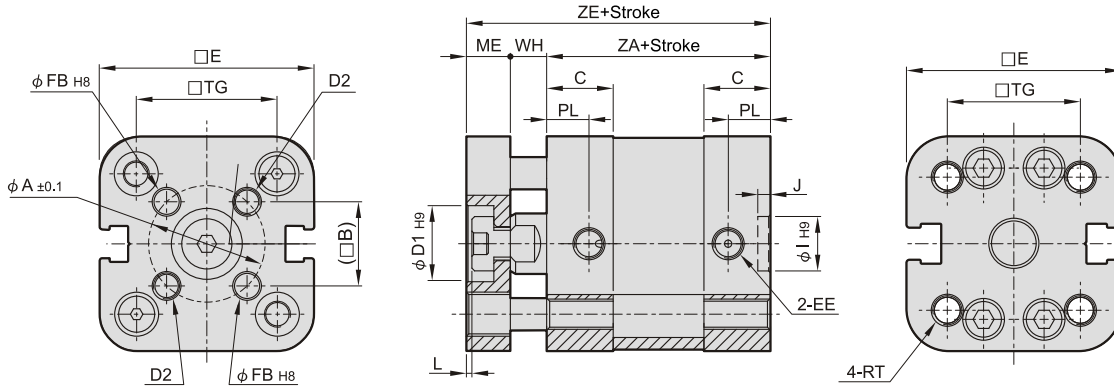

Code Tube I.D.	A	B	C	D1	D2	E	EE	FB	WH	I	J	L	ME	PL	TG	RT	ZA	ZE
20	17	12	11	11	M4×0.7	35.5	M5×0.8	4	6	9	2.1	1	8	7	22	M5×0.8	37	51
25	22	15.6	11	14	M5×0.8	39.5	M5×0.8	5	6	9	2.1	1	8	7	26	M5×0.8	39	53
32	28	19.8	14	17	M5×0.8	47	G1/8	5	7	9	2.1	1.5	10	7.5	32.5	M6×1.0	44	61
40	33	23.3	14	17	M5×0.8	54.5	G1/8	5	7	9	2.1	1.5	10	7.5	38	M6×1.0	45	62
50	42	29.7	14	22	M6×1.0	65.5	G1/8	6	8	12	2.6	1.5	12	7.5	46.5	M8×1.25	45	65
63	50	35.4	14.5	22	M6×1.0	75.5	G1/8	6	8	12	2.6	1.5	12	7.5	56.5	M8×1.25	49	69
80	65	46	15.5	24	M8×1.25	95.5	G1/8	8	10	12	2.6	2	14	8	72	M10×1.5	54	78

FBC

$\phi 20 \sim \phi 25$

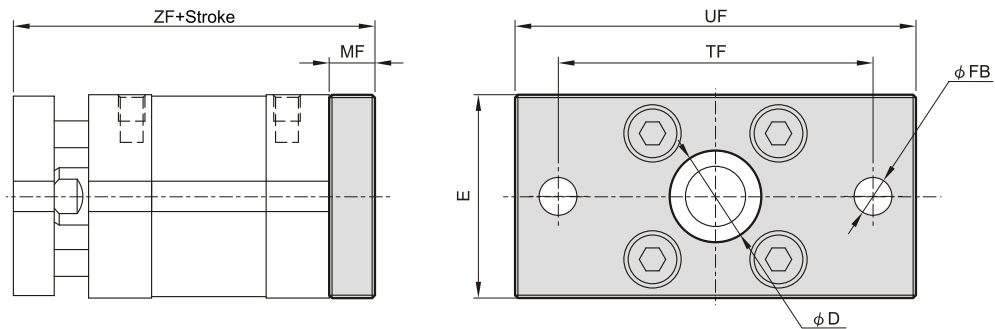

$\phi 32 \sim \phi 80$

Code Tube I.D.	D	E	FB	MF	R	TF	UF	ZF
20	16	35.5	6.6	8	—	55	70	59
25	16	39.5	6.6	8	—	60	76	61
32	30	47	7	10	32	64	80	71
40	35	54.5	9	10	36	72	90	72
50	40	65.5	9	12	45	90	110	77
63	45	75.5	9	12	50	100	120	81
80	45	95.5	12	16	63	126	150	94

