

MGTK Light duty type

MGTX Light duty flange type

MGTB Heavy duty (bush) type

MGTU Heavy duty (linear bearing) type

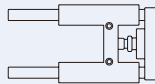

Order example

MGTB - 40 - 100 - RP

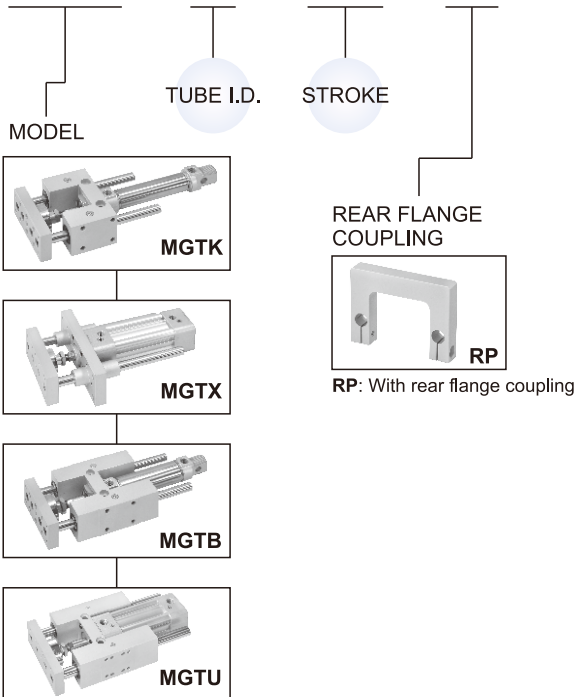

※ Order example for special specification, refer to page J-03.

Features

- The guide units can be assembled to cylinders that then conform to ISO6432.
- Anti rotation guaranteed by use of external guide rods.
- Four self lube bushes or linear bearings enable high loadings and consistent movement.
- Simple to install by universal mounting holes.
- For $\phi 32 \sim \phi 63$ MGTB / U / X is standard with adjustable cushion.
- Flush fitting reed switch.
- Magnetic as standard.

Specification

Model	MGTB, MGTU					
	MGTK		MGTX			
Tube I.D. (mm)	20	25	32	40	50	63
Port size	G1/8		G1/8	G1/4		G3/8
The range of stroke (mm)	Stroke by request					
Medium	Air					
Operating pressure range	0.2~0.7 MPa					
Ambient temperature	-5~+60°C (No freezing)					
Lubrication	Cylinder					
	Guide ※					
Available speed range	50~500 mm/sec					
Sensor switch	RCA			RCI		
	BA20	BA25	—			
Sensor switch holder	BGS20	BGS25	—			

※ Periodically refill of the Lubricating grease is required to enhance the lubricative grade and its lifetime.

RCA sensor switch specification

Model	RCA	RNA	RPA
Switch type	Reed switch	NPN current sinking	
Voltage range	5~240V DC/AC	5 ~ 30V DC	
Current range	100mA max.	200mA max.	
Shock resistance	30G	50G	

※ RCA specification, please refer to page V-05.

RCI sensor switch specification

Model	RCI	RNI	RPI
Switch type	Reed switch	NPN current sinking	PNP current sourcing
Voltage range	5~240V DC/AC	10 ~ 30V DC	
Current range	240mA max.	200mA max.	
Shock resistance	30G	50G	

※ RCI specification, please refer to page V-10.

Mounting

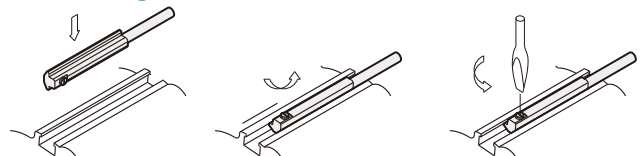

MGTB,MGTU,MGTK

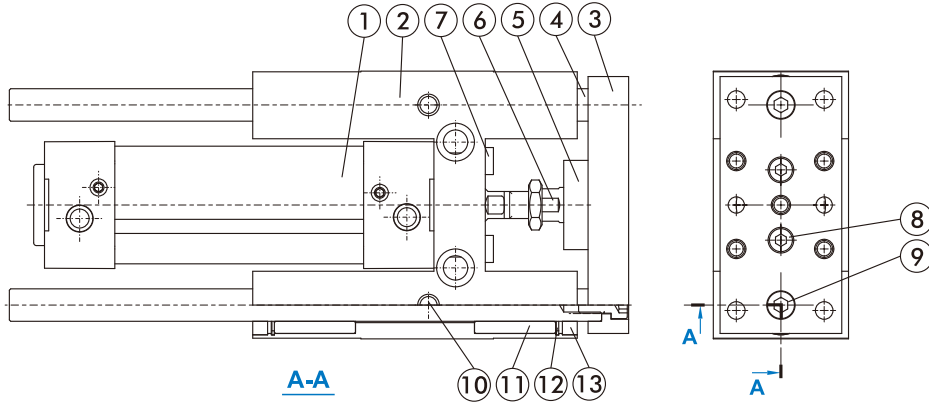

MGTX

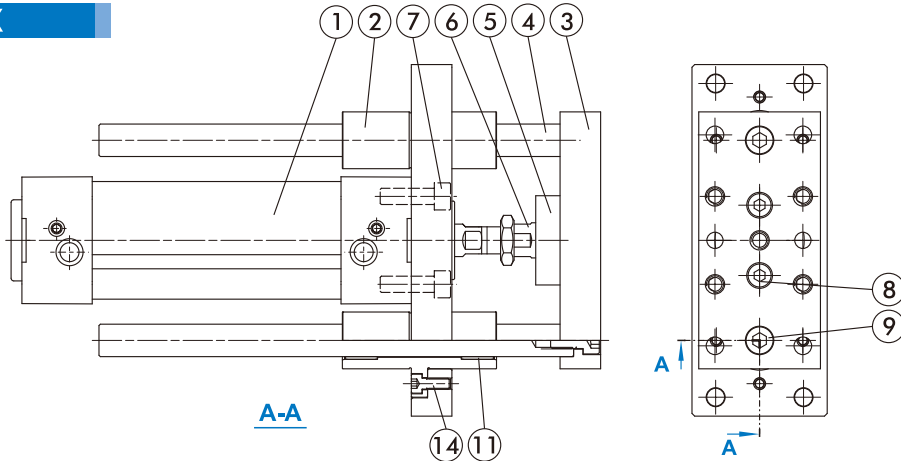

Material

No.	Part name	Material	Note
1	Cylinder	—	$\phi 20, \phi 25$: MCM1 series
			$\phi 32 \sim \phi 63$: MCQ1 series
2	Guide holder	Aluminum alloy	
3	Plate	Aluminum alloy	
4	Guide rod	Medium carbon steel	for MGTB, MGTK, MGTX series
		Bearing steel	for MGTU series
5	Piston rod holder	Carbon steel	
6	Floating connector	Carbon steel	
7	Bolt	SCM	
8	Bolt	SCM	
9	Bolt	SCM	
10	Oiler	Copper	
11	Rod bush	Copper	
12	Snap ring	Spring steel	
13	Wiper seal	NBR	
14	Bolt	SCM	

TWIN-GUIDE CYLINDERS

MGTK (Oilless bush guide)

$\phi 20, \phi 25$

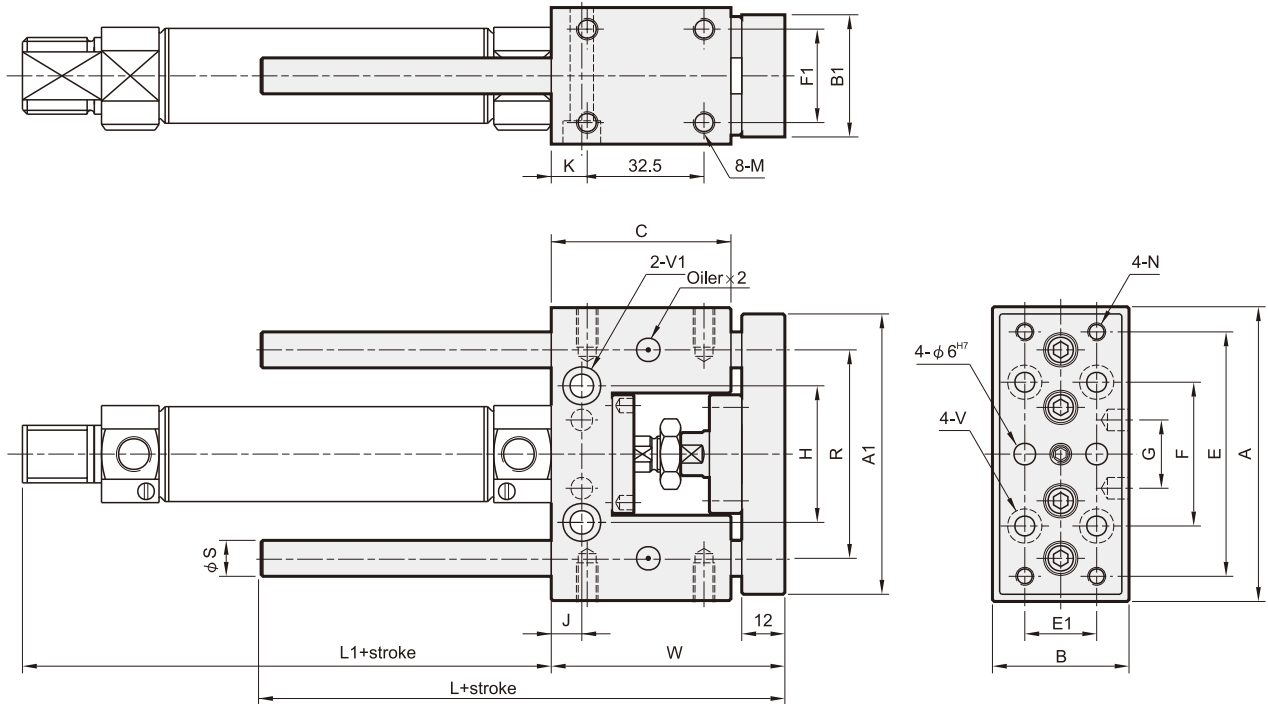

Dimensional table

Code Tube I.D.	A	A1	B	B1	C	E	E1	F	F1	G	H	J	K	L	L1	M	N	R	S	V	V1	W
20	82	78	38	34	50	68	20	40	26	19	38	8.5	5	85	88	M6,(D)11	M5	58	10	$\phi 5.5, \phi 9.5(D)5.4$	$\phi 6.5, \phi 10.5(D)6.5$	65
25	82	78	38	34	50	68	20	40	26	19	38	8.5	5	85	89	M6,(D)11	M5	58	10	$\phi 5.5, \phi 9.5(D)5.4$	$\phi 6.5, \phi 10.5(D)6.5$	65

Maximum allowable torque moment

Max. allowable load

MGTK $\phi 20, \phi 25$

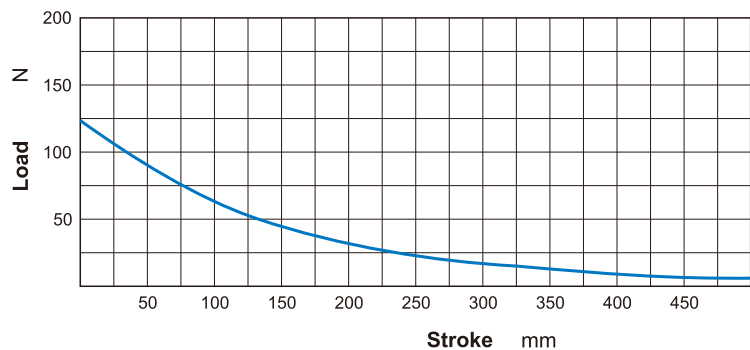
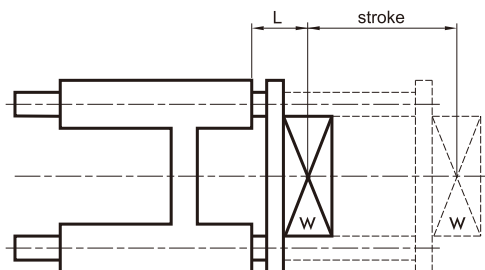

TWIN-GUIDE CYLINDERS

MGTB (Brass bush guide)

MGTU (Linear bearing guide)

$\phi 20, \phi 25$

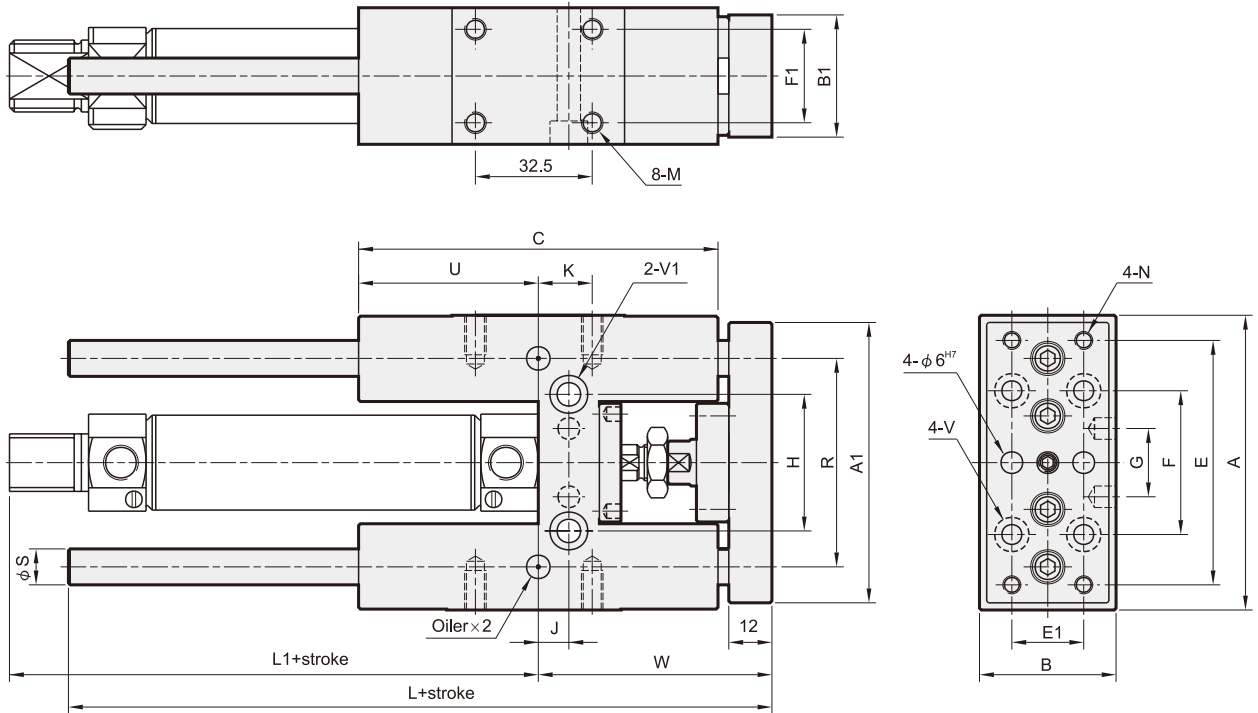

Dimensional table

Code Tube I.D.	A	A1	B	B1	C	E	E1	F	F1	G	H	J	K	L	L1	M	N	R	S	U	V	V1	W
20	82	78	38	34	100	68	20	40	26	19	38	8.5	15	135	88	M6,(D)11	M5	58	10	50	$\phi 5.5, \phi 9.5(D)5.4$	$\phi 6.5, \phi 10.5(D)6.5$	65
25	82	78	38	34	100	68	20	40	26	19	38	8.5	15	135	89	M6,(D)11	M5	58	10	50	$\phi 5.5, \phi 9.5(D)5.4$	$\phi 6.5, \phi 10.5(D)6.5$	65

Maximum allowable torque moment

Max. allowable load

MGTB.MGTU $\phi 20, \phi 25$

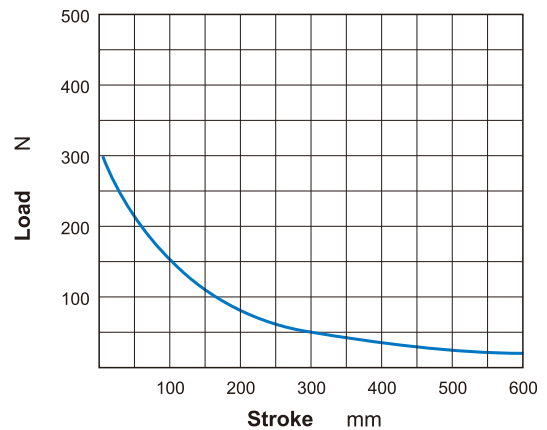
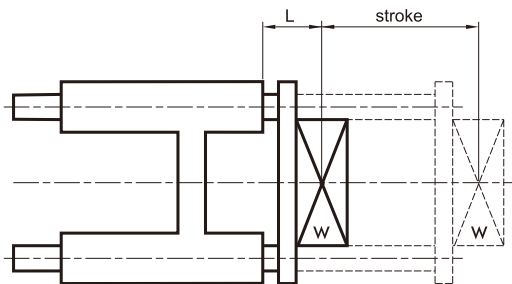

TWIN-GUIDE CYLINDERS

Sensor switch: RCA
Sensor switch band: BA**

Code Tube I.D.	A	B	C	D	E
20	33	52	9	18	26
25	35.5	54.5	9	18	26

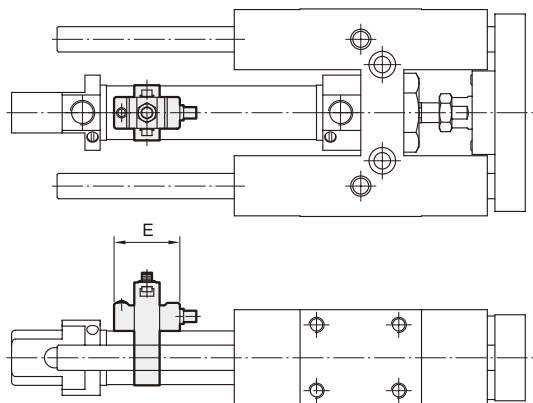
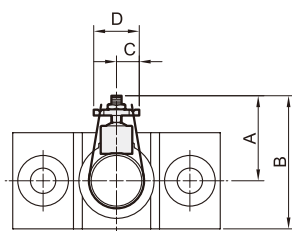

Sensor switch: RCA
Sensor switch band: BGS**

Code Tube I.D.	A	B	C	D	E
20	25	44	18	33	26
25	25.5	44.5	18.5	33.5	26

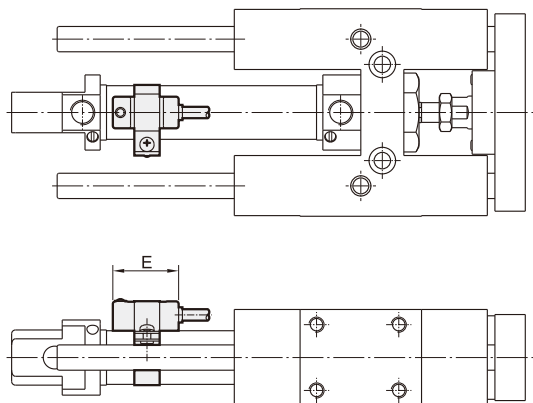
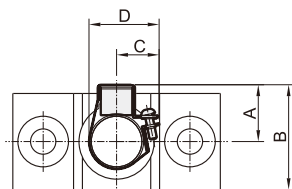

Sensor switch: RCM
Sensor switch band: BM**

Code Tube I.D.	A	B	C	D	E
20	22	41	10	16	28
25	25	44	10	16	28

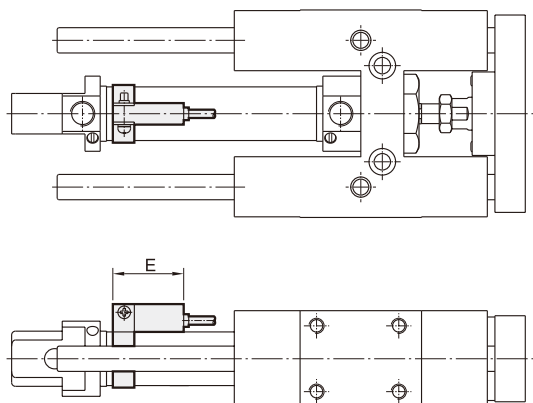
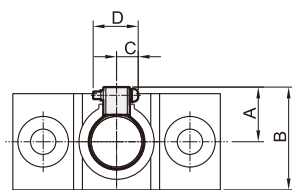

MGTB (Brass bush guide)

MGTU (Linear bearing guide)

Tube I.D. : $\phi 32$

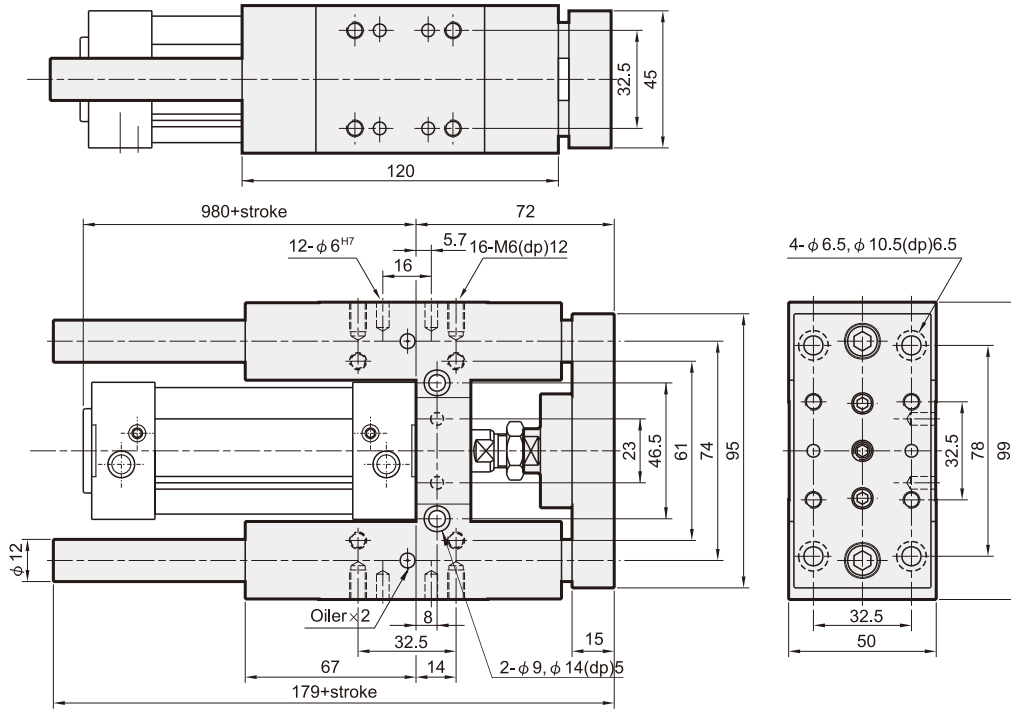

Maximum allowable torque moment

Max. allowable load

MGTB.MGTU $\phi 32$

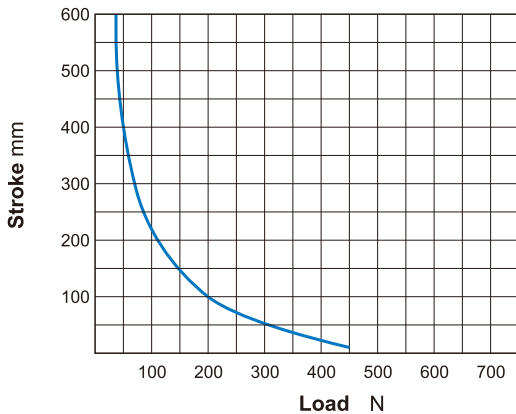
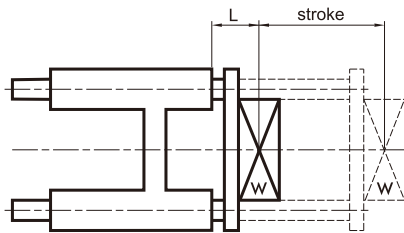

Installation of sensor switch $\phi 32 \sim \phi 63$

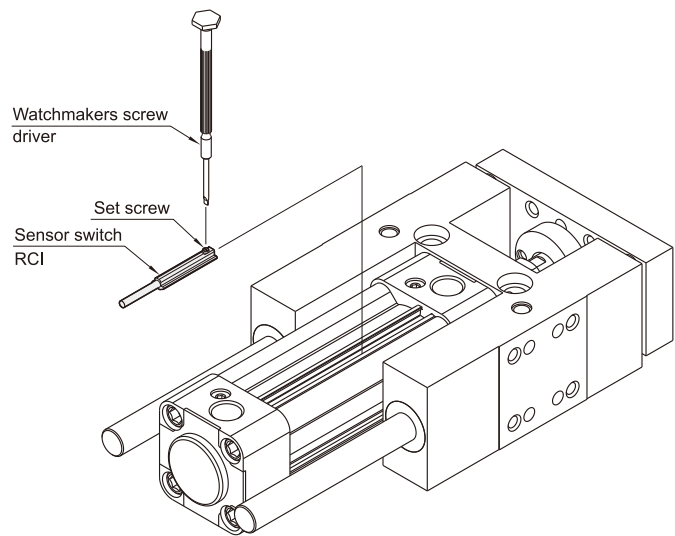

MGTB (Brass bush guide)

MGTU (Linear bearing guide)

$\phi 40$

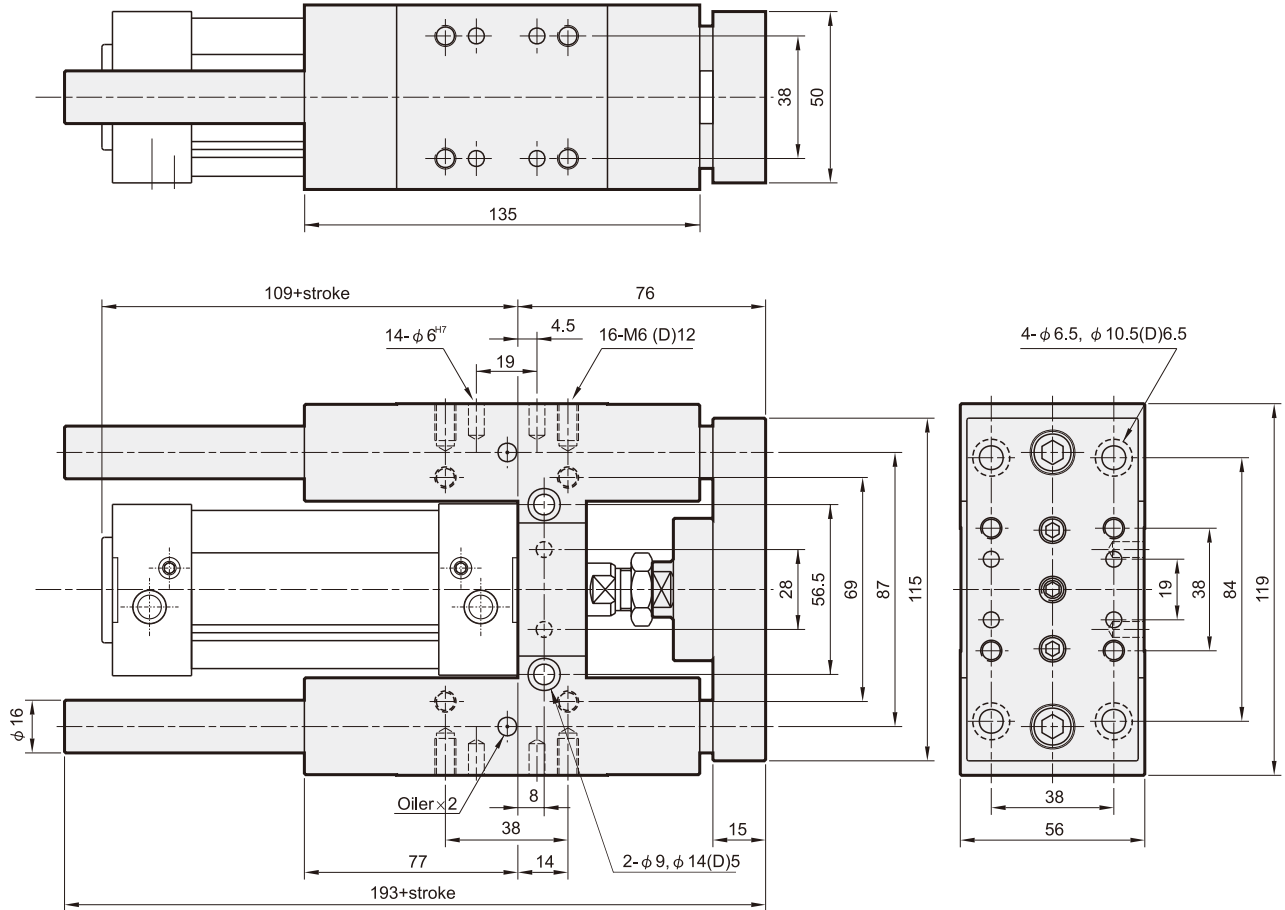

Maximum allowable torque moment

Max. allowable load

MGTB.MGTU $\phi 40$

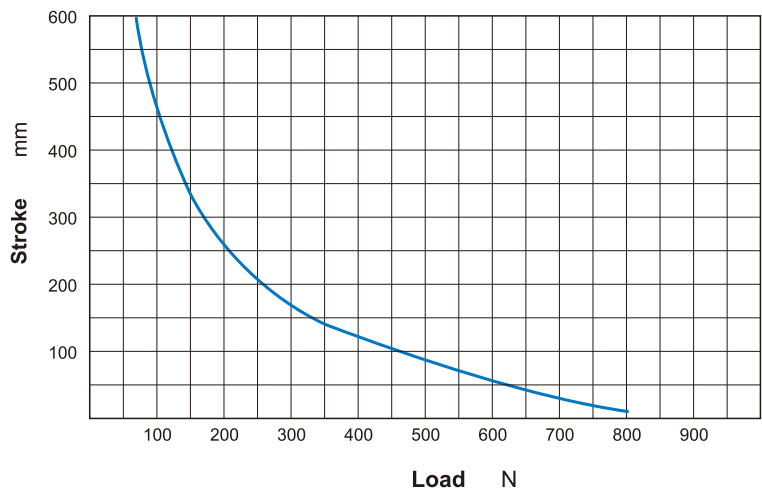
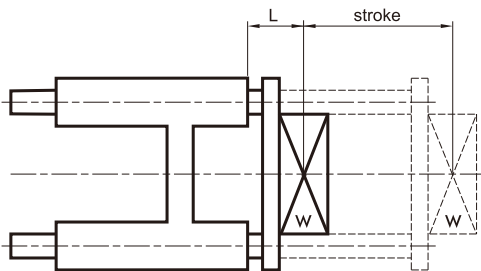

TWIN-GUIDE CYLINDERS

MGTB (Brass bush guide)

MGTU (Linear bearing guide)

$\phi 50, \phi 63$

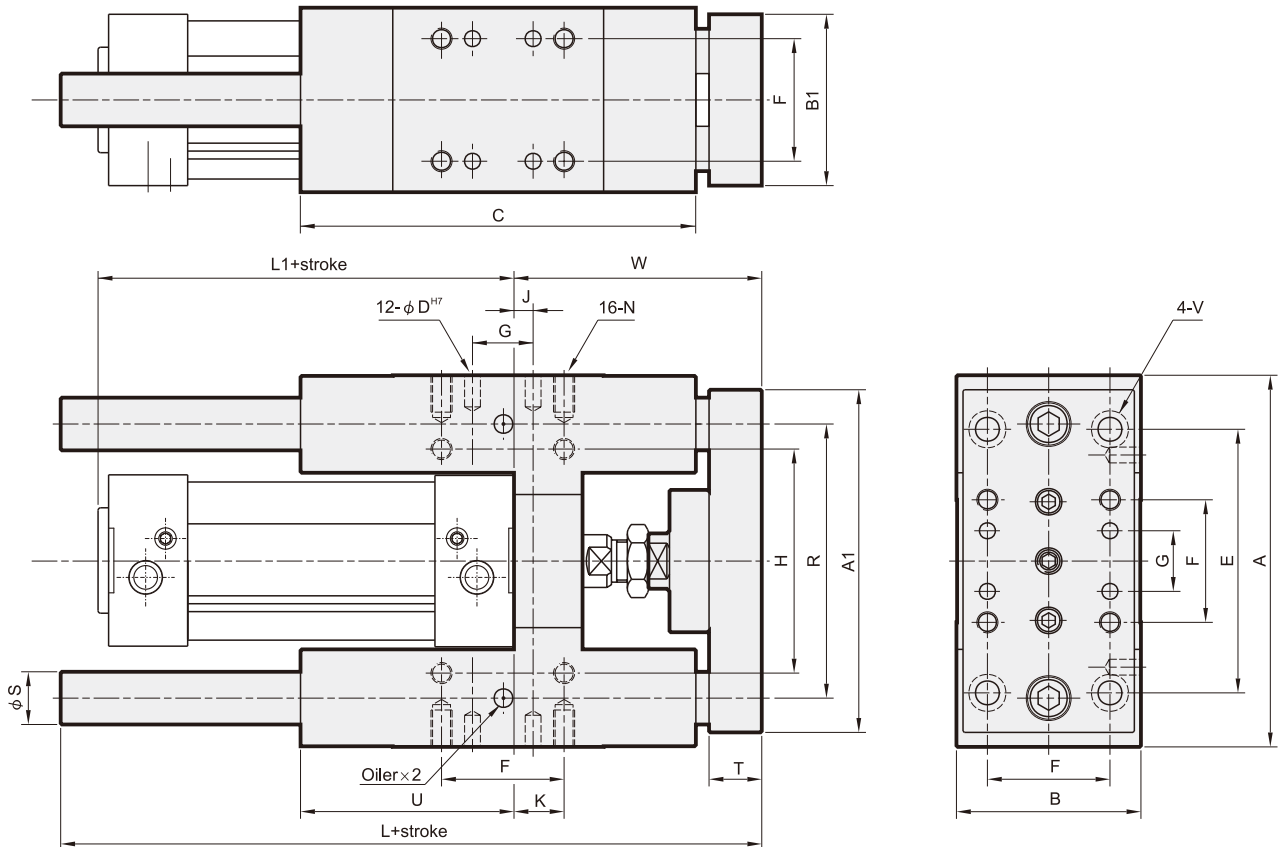

Dimensional table

Code Tube I.D.	A	A1	B	B1	C	D	E	F	G	H	J	K	L	L1	N	R	S	T	U	V	W
50	141	135	70	65	150	6	100	46.5	23	85	7.5	19	216	110	M8,(D)14	104	20	20	81	$\phi 9, \phi 14(D)8.5$	94
63	156	150	80	75	150	6	105	56.5	28	100	5	19	230	125	M8,(D)14	119	20	20	96	$\phi 9, \phi 14(D)8.5$	94

Maximum allowable torque moment

Max. allowable load

MGTB.MGTU $\phi 50, \phi 63$

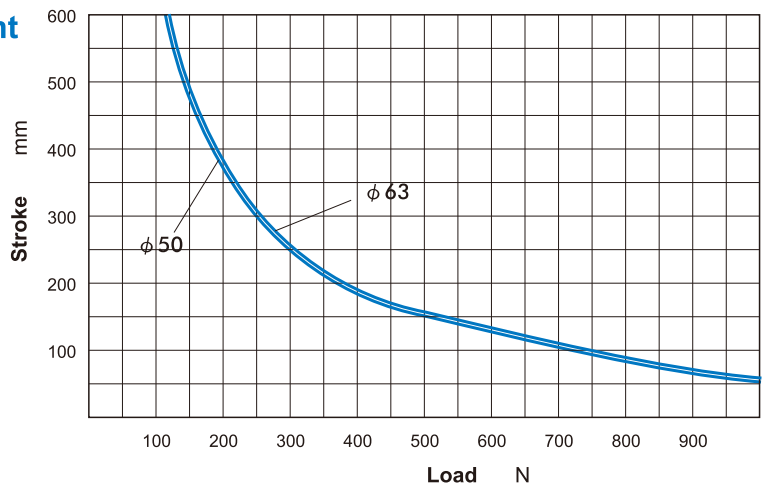
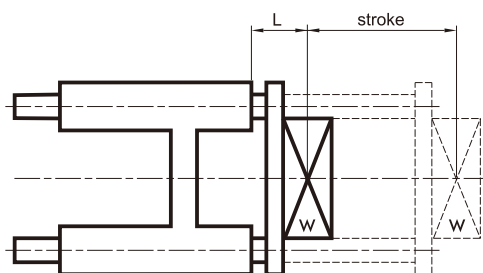

MGTX (Flange type)

$\phi 32$

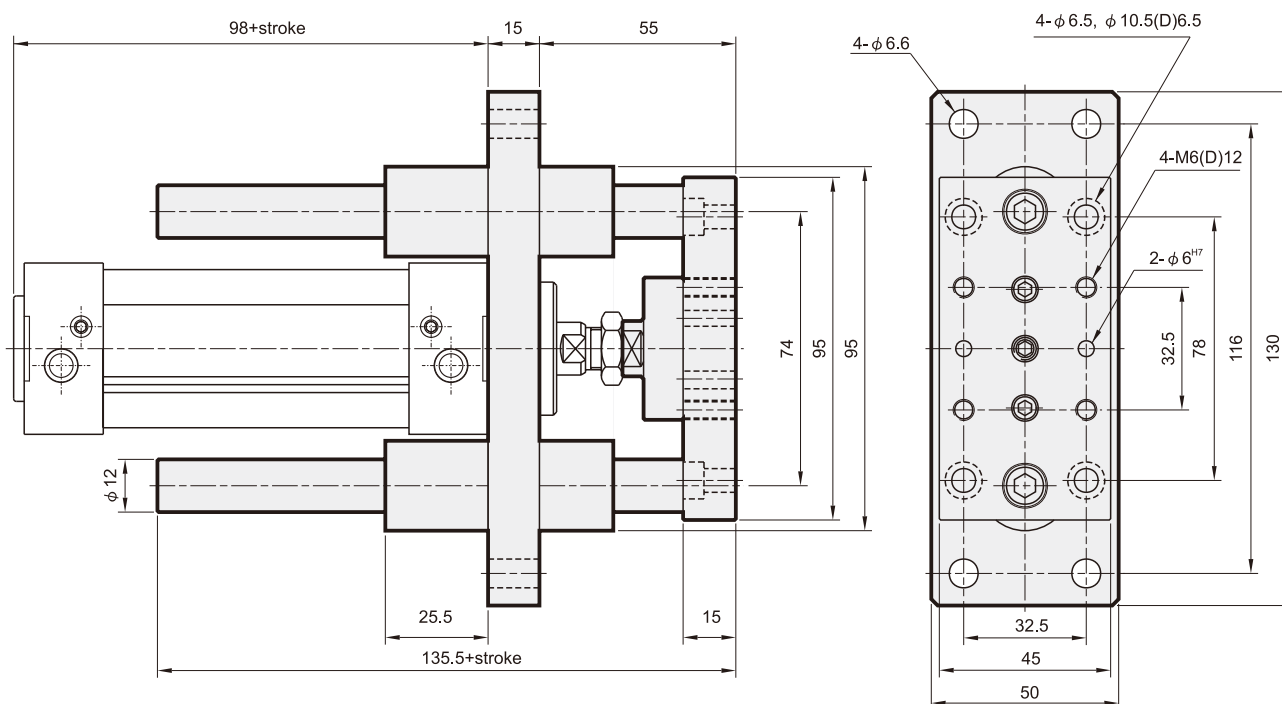

Maximum allowable torque moment

Max. allowable load

MGTX $\phi 32$

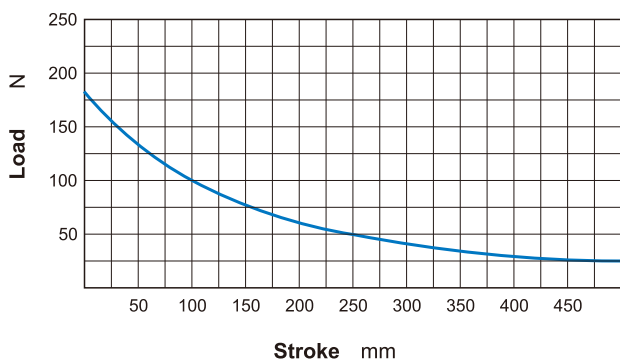
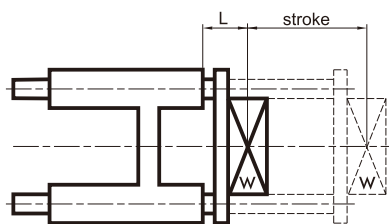

Installation of sensor switch $\phi 32 \sim \phi 63$

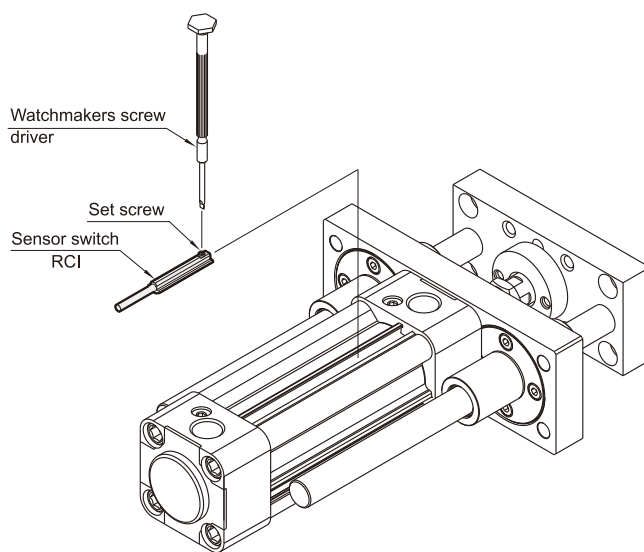

TWIN-GUIDE CYLINDERS

MGTX (Flange type)

$\phi 40, \phi 50, \phi 63$

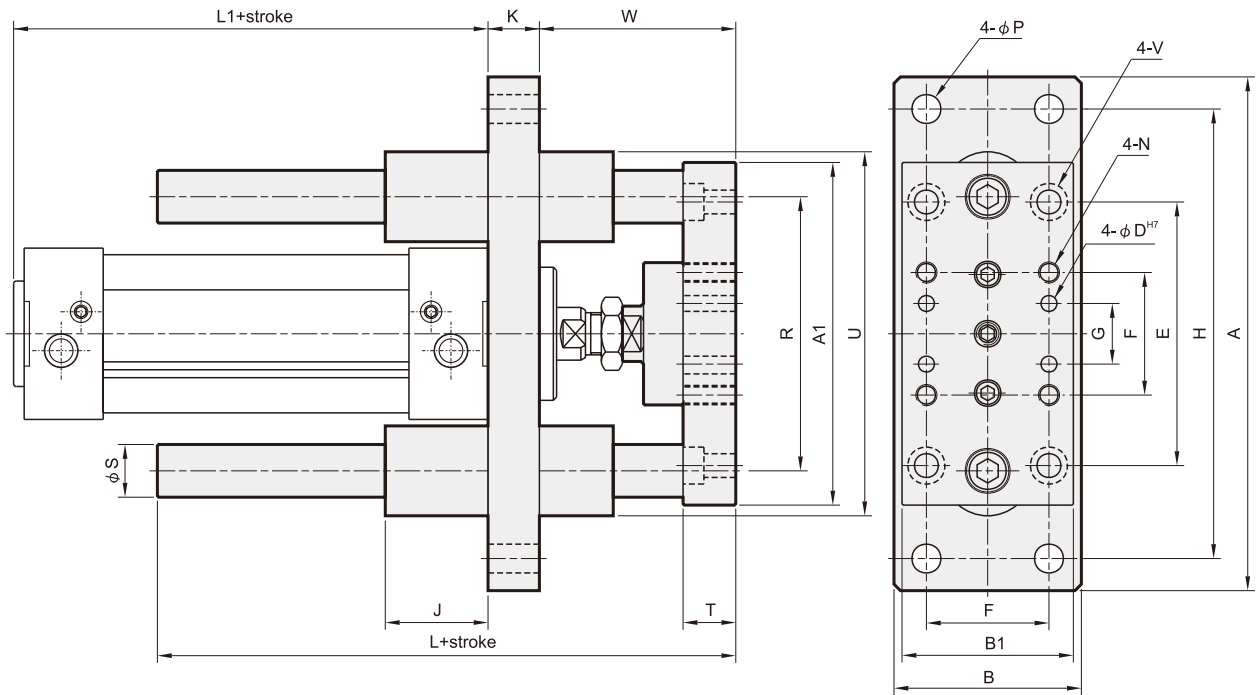

Dimensional table

Code Tube I.D.	A	A1	B	B1	D	E	F	G	H	J	K	L	L1	N	P	R	S	T	U	V	W
40	160	115	55	54	6	84	38	19	140	32	15	148	109	M6,(D)12	$\phi 9$	87	16	15	115	$\phi 6.5, \phi 10.5(D)6.5$	61
50	180	135	70	65	6	100	46.5	23	160	36	20	170	110	M8,(D)14	$\phi 9$	104	20	20	136	$\phi 9, \phi 14(D)8.5$	74
63	195	150	80	75	6	105	56.5	28	175	36	20	170	125	M8,(D)16	$\phi 9$	119	20	20	151	$\phi 9, \phi 14(D)8.5$	74

Maximum allowable torque moment

Max. allowable load

MGTX $\phi 40 \sim \phi 63$

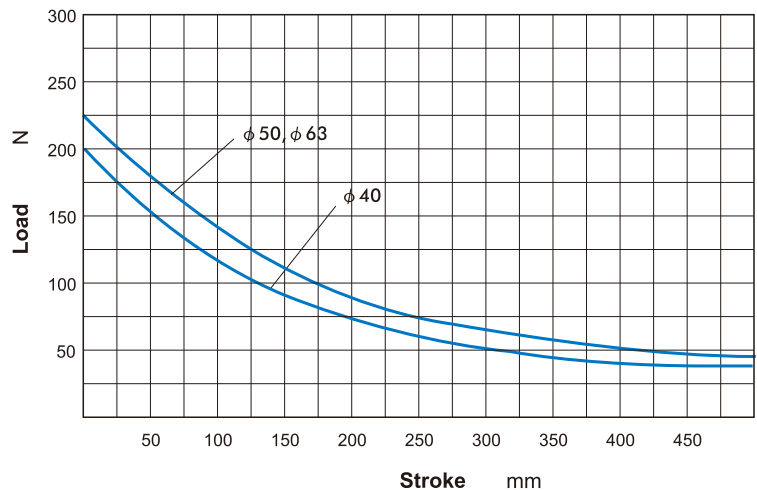
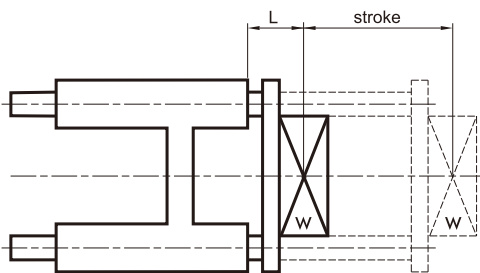

MGT* Rear flange coupling $\phi 20, \phi 25$

TWIN-GUIDE CYLINDERS

MGTK

$\phi 20, \phi 25$

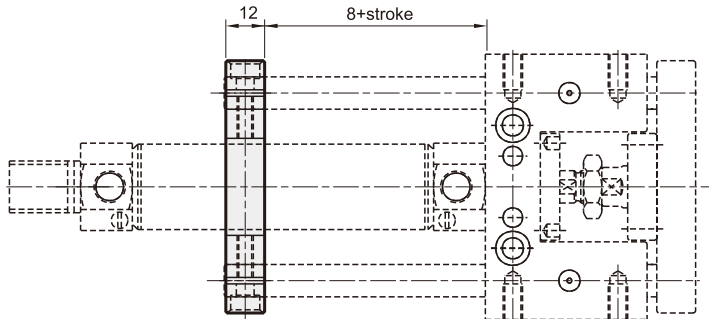
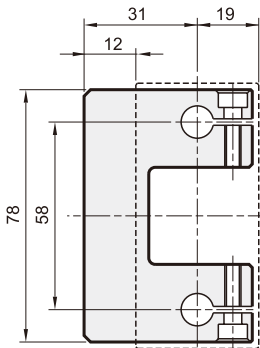

MGTB

$\phi 20, \phi 25$

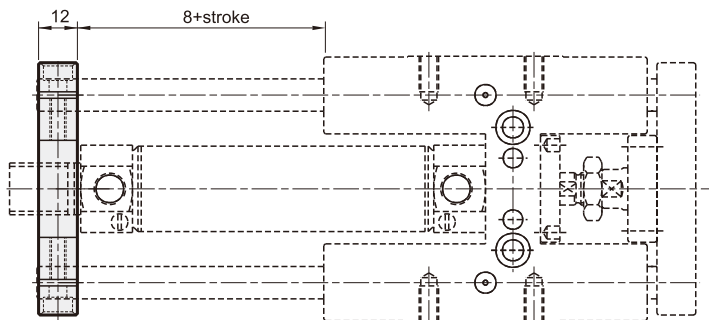
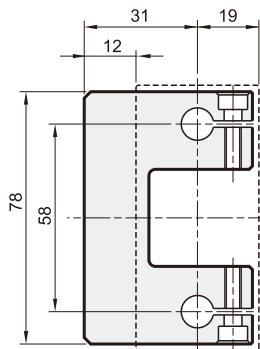

Building material: aluminium alloy
2 Clamps screws are included in the supply

Maximum allowable torque moment

Max. allowable load

MGTB.MGTU

Inflection of guide stems is due to their weight summed to the load of 1Kg.related to the stroke.

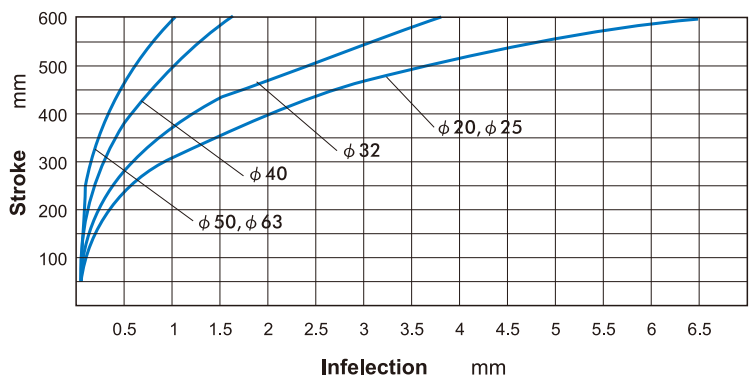
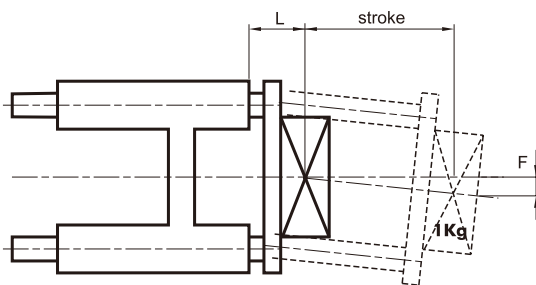

Weight of the guide cylinder

unit: kg

Tube I.D.	Basic weight	Stroke 25 mm	Basic weight	Stroke 25 mm	Basic weight	Stroke 25 mm
	MGTK (Oilless bush guide)		MGTB (Brass bush guide)		MGTU (Linear bushing guide)	
20	0.690	0.050	1.090	0.050	0.967	0.050
25	0.716	0.058	1.137	0.058	1.015	0.058

MGT* Rear flange coupling $\phi 32, \phi 40, \phi 50, \phi 63$

TWIN-GUIDE CYLINDERS



MGTX $\phi 32, \phi 40, \phi 50, \phi 63$

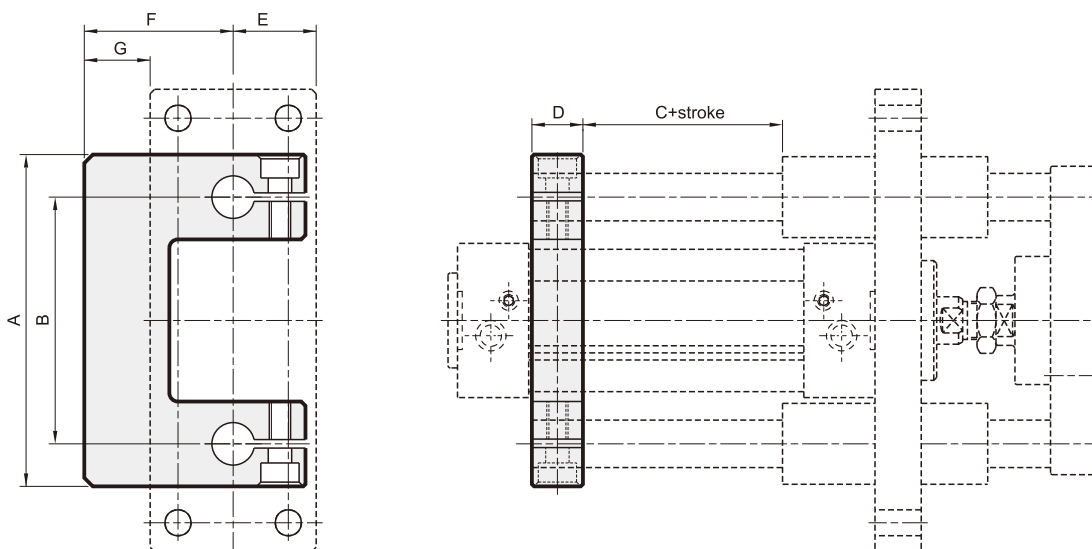

MGTB **MGTU** $\phi 32, \phi 40, \phi 50, \phi 63$

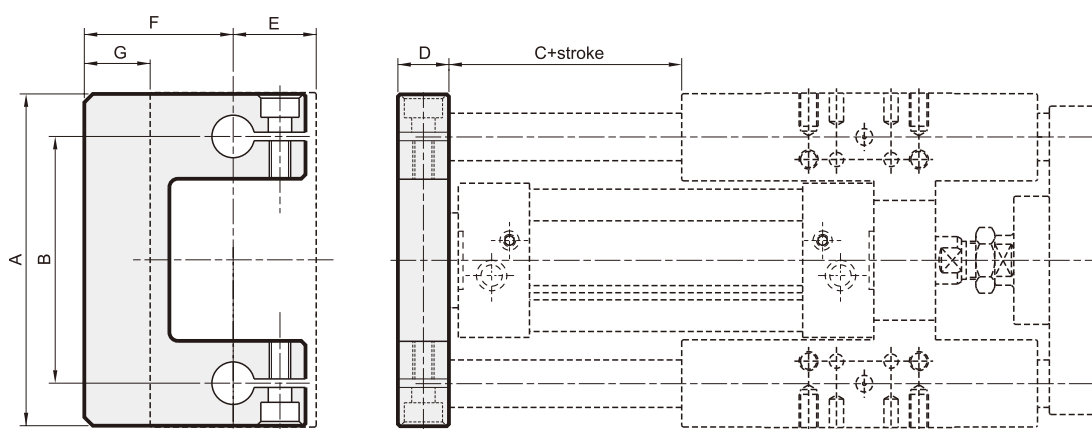

Dimensional table

Code Tube I.D.	A	B	C	D	E	F	G
32	95	74	25	15	25	47	22
40	115	87	20	20	28	52.5	24.5
50	135	104	20	20	35	67.5	32.5
63	150	119	20	20	40	78	38

Building material: aluminium alloy
2 Clamps screws are included in the supply

Weight of the guide cylinder

unit: kg

Tube I.D.	Basic weight	Stroke 25 mm	Basic weight	Stroke 25 mm	Basic weight	Stroke 25 mm
	MGTB (Brass bush guide)		MGTU (Linear bushing guide)		MGTX (Brass bush guide)	
32	2.060	0.100	1.918	0.100	1.274	0.100
40	3.423	0.159	3.113	0.159	2.082	0.159
50	5.584	0.240	5.162	0.240	3.440	0.240
63	6.816	0.250	6.390	0.250	4.221	0.250

