

Features

■ Non lubrication

Special housing and bushing enables self lubrication of piston rod.

■ High quality long service life

Hard anodised aluminium cylinder tubes offer a high resistance to corrosion and low internal friction.

■ ISO-VDMA standard specification

Conforms to ISO-6431 and VDMA 24562 specification enabling worldwide interchangeability.

■ Cylinder mountings

Available with comprehensive internationally recognised range of fixed and flexible mountings.

Table for standard stroke

Tube I.D.	Stroke (mm)
φ 32,40	50,75,100,125,150,175,200,250,300,350,400,450,500
φ 50,63	↑ 600
φ 80,100,125,160	↑ 600,700
φ 200	↑ 600,700,800,900,1000,1500

- Stroke out of specification is also available.
- Please consult us if stroke out of specification.

Specification



Model	MCQV2			MCQV		
Tube I.D. (mm)	32,40	50,63	80,100	125	160	200
Medium	Air					
Operating pressure range	0,05~1 MPa					
Proof pressure	1.5 MPa					
Ambient temperature	-5~+60°C (No freezing)					
Available speed range	50~500 mm/sec					
Sensor switch (※)	RCA					
Sensor switch holder	HV1	HV2	HV3	HV4	PM16	HA5V

※ RCA specification, please refer to page V-05.

Order example

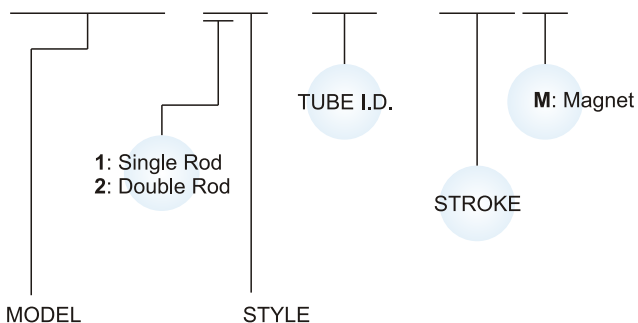
MCQV2 - 11 - 40 - 100 M



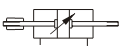

MODEL		STYLE		
Model	Tube I.D.	Code	Symbol	Description
MCQV2	φ 32~ φ 100	1 1		Double acting / Male thread
MCQV	φ 125~ φ 200	2 1		Double rod / Male thread
		2 7		Double rod / Adjustable male thread (Please mark "adjustable distance(mm)" at order list)

※ Order example for special specification, refer to page J-03.

Mounting accessories

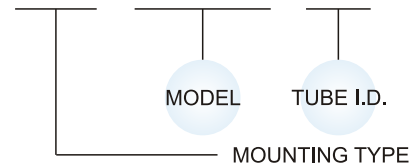
FAC - MCQV - 40 ※ φ 200 only for Y&I connector

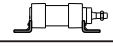
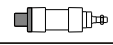
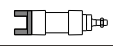
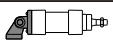
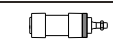
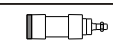
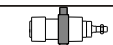
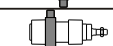
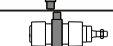
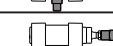

	LB
	CA
	CB
	CDB (+CB+Pin)
	FAC
	FBC
	TA
	TB
	TC
	Y
	I

MCQV-11 Inside structure & Parts list

ISO-VDMA STANDARD CYLINDERS



Single rod 11 type

ϕ 32~ ϕ 100

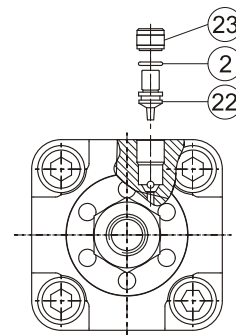
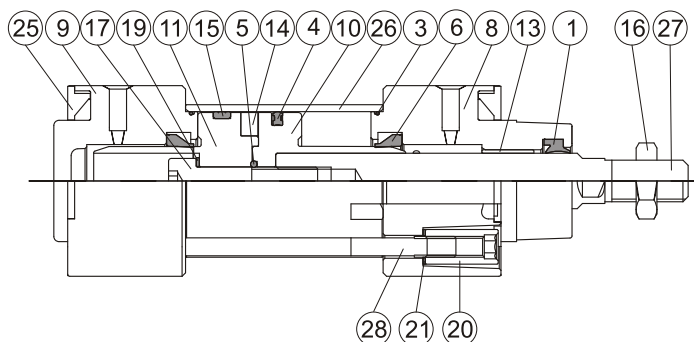

ϕ 125~ ϕ 200

ϕ 200

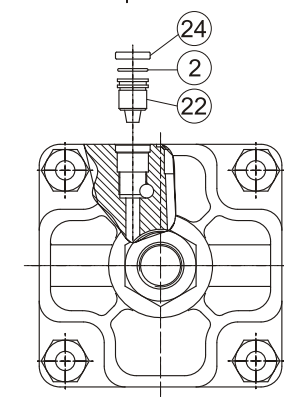
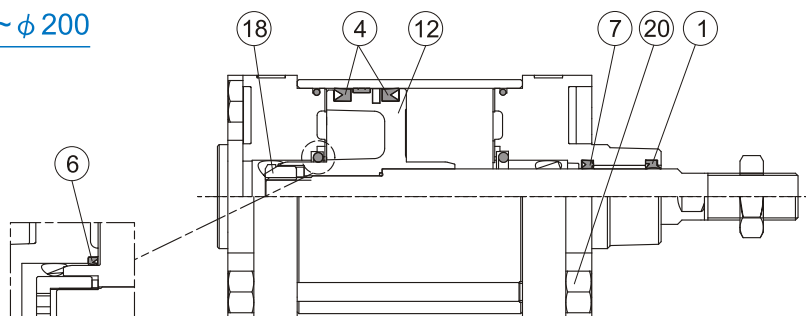

No.	Part name	Material	Q'y	Component parts (inclusion)		Repair kits (inclusion)		Note
				ϕ 32~ ϕ 100	ϕ 125~ ϕ 200	ϕ 32~ ϕ 100	ϕ 125~ ϕ 200	
01	Rod packing	NBR	1	●	●	●	●	
02	O-ring	NBR	2	●	●	●	●	
03	O-ring	NBR	2	●	●	●	●	
04	Piston packing	NBR	1 or 2	●	●	●	●	ϕ 125~ ϕ 200 (Q'y 2)
05	O-ring	NBR	1	●	●	●	●	
06	Cushion packing	NBR	2	●	●	●	● (※)	
07	Rod packing	NBR	1		●		●	
08	Rod cover	Aluminum alloy	1	●	●			
09	Head cover	Aluminum alloy	1	●	●			
10	Piston-R	Aluminum alloy	1	●				
11	Piston-H	Aluminum alloy	1	●				
12	Piston	Aluminum alloy	1		●			
13	Bush	Bearing alloy	1	●	●			
14	Magnet ring	Magnet material	1	◎	◎			◎ Option
15	Wear ring	Teflon	1	●	●			
16	Nut	Carbon steel	1	●	●			
17	Bolt	Carbon steel	1	●				
18	Piston nut	Carbon steel	1		●			
19	Washer	Carbon steel	1	●	●			ϕ 32 does not contain item #19
20	Tie rod nut	Carbon steel	8	●	●			
21	Tie rod washer	Carbon steel	8	●				
22	Needle valve	Copper alloy	2	●	●			
23	Insert nut	Copper alloy	2	●				
24	Needle valve washer	Carbon steel	2		●			
25	Cover plate	Plastic	2	●				
26	Cylinder tube	Aluminum alloy	1					
27	Piston rod	Carbon steel	1					
28	Tie rod	Carbon steel	4					

(※) Cushion packing is not included in ϕ 200 repair kits.



MCQV-2* Inside structure & Parts list

ISO-VDMA STANDARD CYLINDERS



mindman

Double rod 21 / 27 type

ϕ 32~ ϕ 100

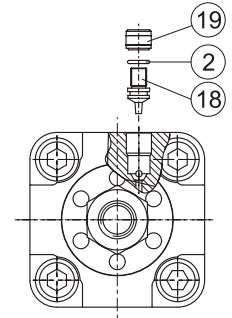
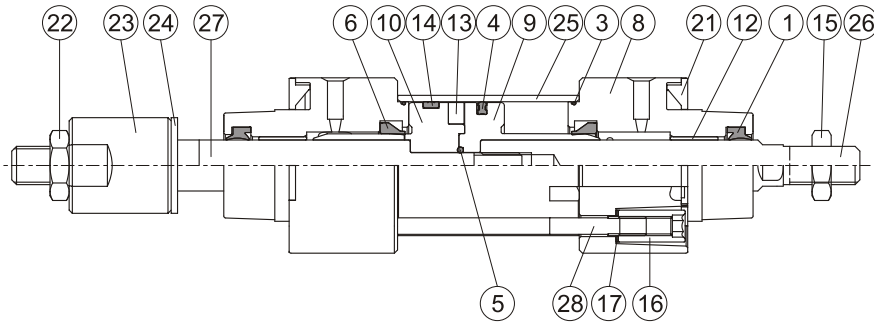

ϕ 125~ ϕ 200

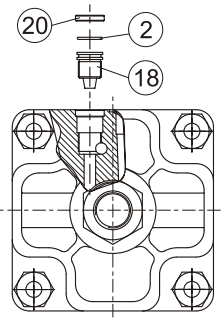
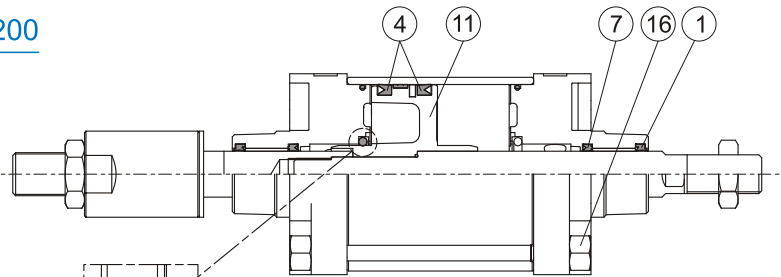

ϕ 200

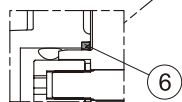

No.	21 type		27 type		Part name	Material	Q'y	Component parts (inclusion)		Repair kits (inclusion)		Note
	A	B	A	B				ϕ 40~ ϕ 100	ϕ 125~ ϕ 200	ϕ 40~ ϕ 100	ϕ 125~ ϕ 200	
01	●	●	●	●	Rod packing	NBR	2	●	●	●	●	
02	●	●	●	●	O-ring	NBR	2	●	●	●	●	
03	●	●	●	●	O-ring	NBR	2	●	●	●	●	
04	●	●	●	●	Piston packing	NBR	1 or 2	●	●	●	●	ϕ 125~ ϕ 200 (Q'y 2)
05	●	●	●	●	O-ring	NBR	1	●	●	●	●	
06	●	●	●	●	Cushion packing	NBR	2	●	●	●	● (*)	
07		●		●	Rod packing	NBR	2		●		●	
08	●	●	●	●	Rod cover	Aluminum alloy	2	●	●			
09	●		●		Piston-R	Aluminum alloy	1	●				
10	●		●		Piston-H	Aluminum alloy	1	●				
11		●		●	Piston	Aluminum alloy	1		●			
12	●	●	●	●	Bush	Bearing alloy	2	●	●			
13	◎	◎	◎	◎	Magnet ring	Magnet material	1	◎	◎			◎ Option
14	●	●	●	●	Wear ring	Teflon	1	●	●			
15	●	●	●	●	Screw	Carbon steel	1	●	●			
16	●	●	●	●	Tie rod nut	Carbon steel	8	●	●			
17	●		●		Tie rod washer	Carbon steel	8	●				
18	●	●	●	●	Needle valve	Copper alloy	2	●	●			
19	●		●		Insert nut	Copper alloy	2	●				
20		●		●	Needle valve washer	Carbon steel	2		●			
21	●		●		Cover plate	Plastic	2	●				
22	●	●	●	●	Nut	Carbon steel	1	●	●			
23			●	●	Adjustable nut	Carbon steel	1					
24			●	●	Gasket	PU	1					
25	●	●	●	●	Cylinder tube	Aluminum alloy	1					
26	●	●	●	●	Piston rod #1	Carbon steel	1					
27	●	●	●	●	Piston rod #2	Carbon steel	1					
28	●	●	●	●	Tie rod	Carbon steel	4					

A: ϕ 40~ ϕ 100, B: ϕ 125~ ϕ 200 (*) Cushion packing is not included in ϕ 200 repair kits.



mindman

■ Order example of component parts

CP – MCQV2 – 2 – 40 M – G

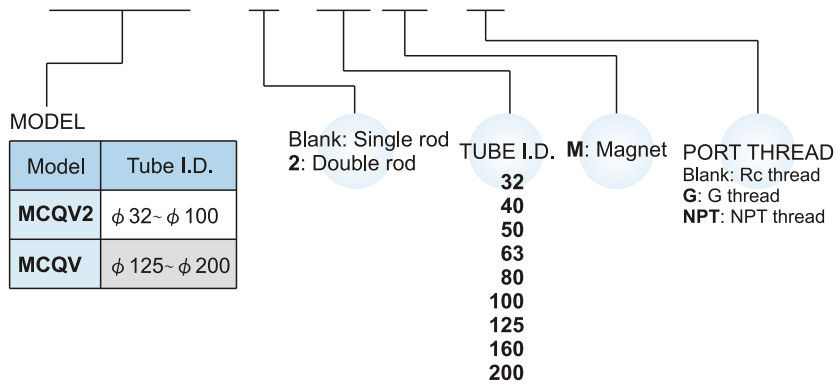

■ Order example of repair kits

PS – MCQV2 – 2 – 40 – XB6

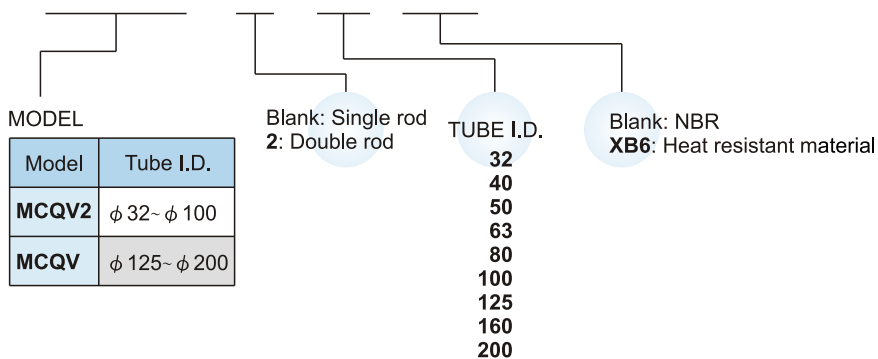

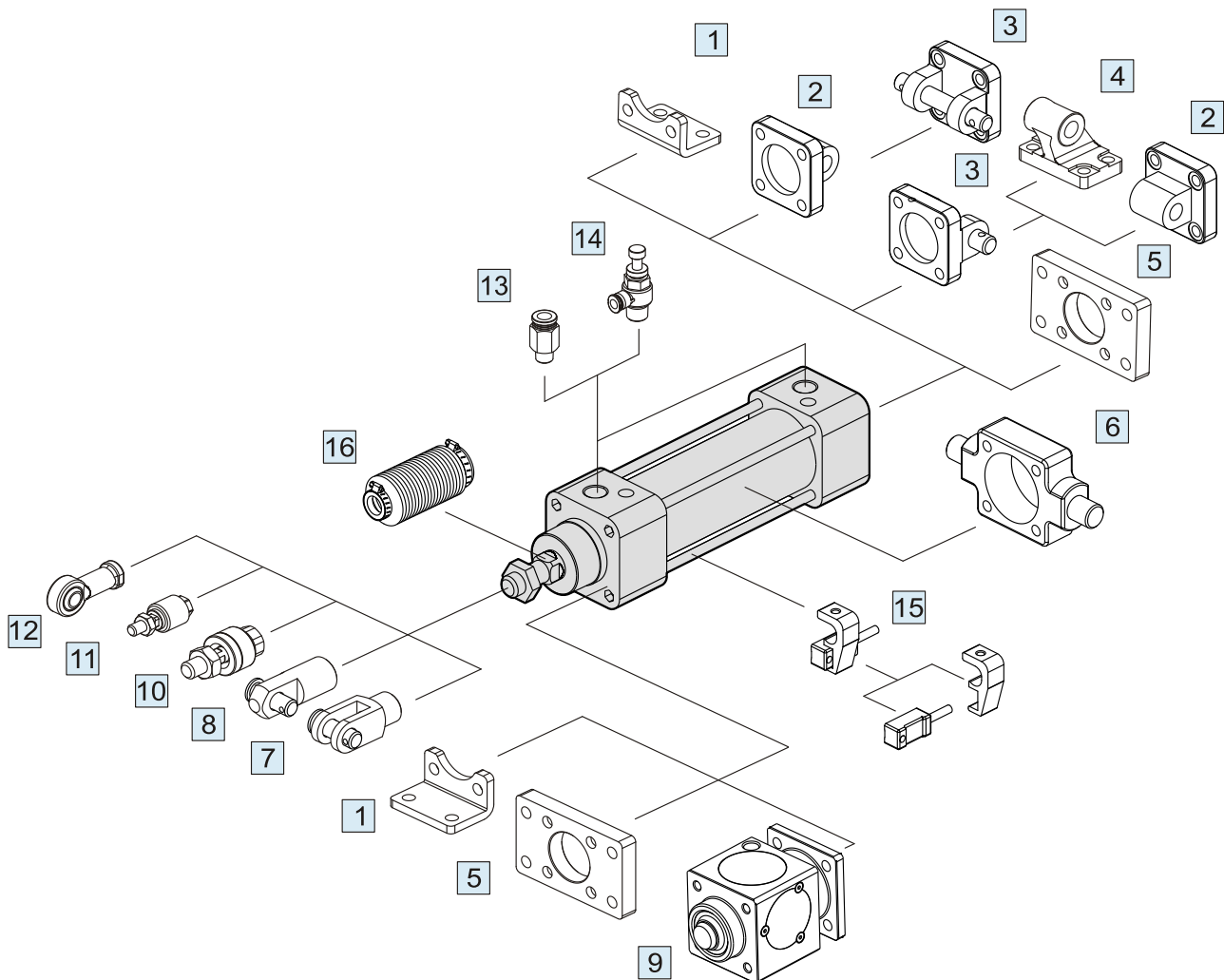

No.	Accessories	Page
1	Mounting accessories LB	J-42
2	Mounting accessories CA	J-44
3	Mounting accessories CB+PIN	J-44, 52
4	Mounting accessories CDB	J-45
5	Mounting accessories FAC / FBC	J-43
6	Mounting accessories TA / TB / TC	J-45, 46
7	Accessories Y+PIN	J-52
8	Accessories I+PIN	J-52

No.	Accessories	Page
9	Locking unit MCBQV*	J-75
10	Floating joint MFC	V-01
11	Floating joint MFCS	V-03
12	Female rod ends PHS	V-04
13	Fitting PC (PISCO)	H-03
14	Speed controller JSC (PISCO)	H-14
15	Sensor switch RCA+HV*	V-05
16	Protective bellows kit	—

11

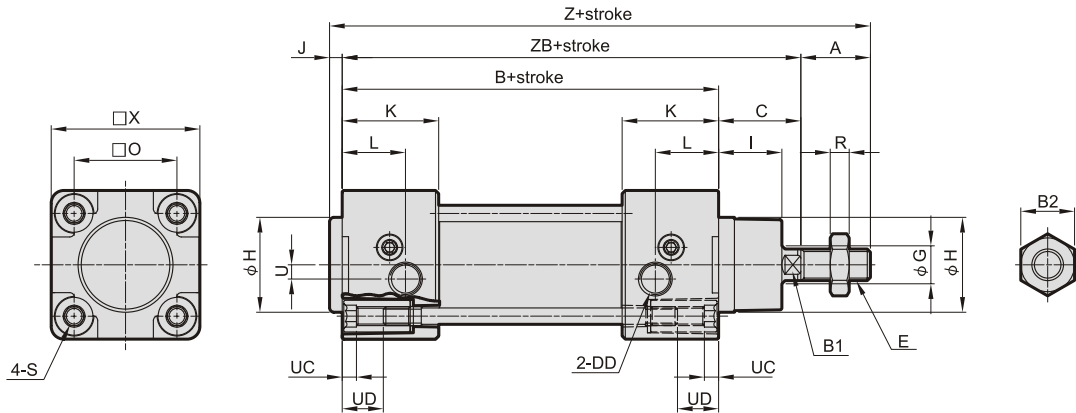

21

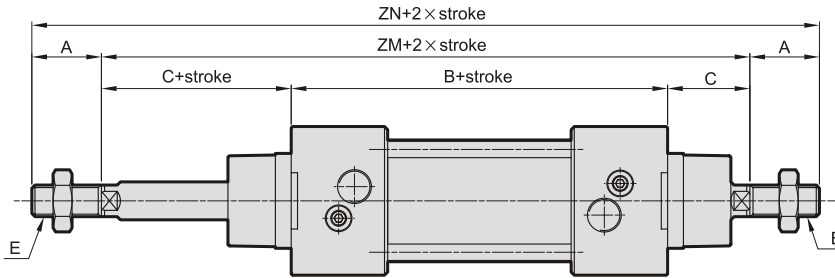

27

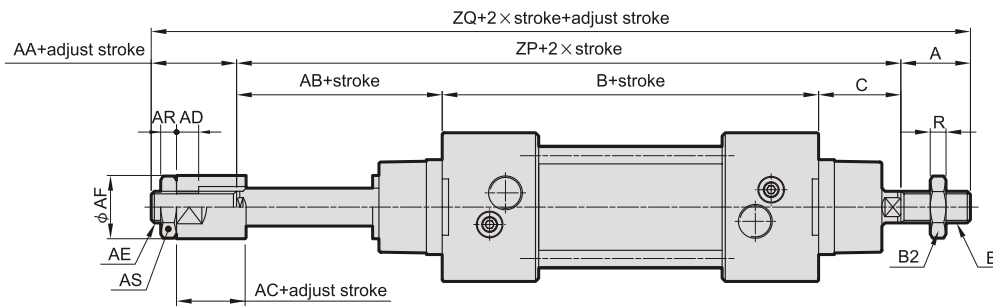

Code Tube I.D.	A	AA	AB	AC	AD	AE	AF	AR	AS	B	B1	B2	C	DD	E	G	H	I	J	K	L	O	R
32	22	16	26	12	7	M10 x 1.25	20	5	17	94	10	17	26	G1/8	M10 x 1.25	12	30	20	4	30.5	20	32.5	5
40	24	20	27	12	7	M12 x 1.25	30	6	19	105	13	19	30	G1/4	M12 x 1.25	16	35	20.5	4	34	14.5	38	6
50	32	18	34	15	10	M16 x 1.5	40	8	24	106	16	24	37	G1/4	M16 x 1.5	20	40	28	4	31	16	46.5	8
63	32	20	32	15	10	M16 x 1.5	40	8	24	121	16	24	37	G3/8	M16 x 1.5	20	45	26	4	33	16	56.5	8
80	40	32	41	20	14	M22 x 1.5	50	13	32	128	21	30	46	G3/8	M20 x 1.5	25	45	32.5	4	35.5	20.5	72	10
100	40	30	46	20	14	M22 x 1.5	50	13	32	138	21	30	51	G1/2	M20 x 1.5	25	55	37.5	4	37	19	89	10

Code Tube I.D.	S	U	UC	UD	X	Z	ZB	ZM	ZN	ZP	ZQ
32	M6 x 1.0	4.5	4.5	12	47	146	120	146	190	146	184
40	M6 x 1.0	5.3	4.5	12	55	163	135	165	213	162	206
50	M8 x 1.25	8.5	4.5	16	65	179	143	180	244	177	227
63	M8 x 1.25	8	4.5	16	78	194	158	195	259	190	242
80	M10 x 1.5	9	4.5	18	95	218	174	220	300	215	287
100	M10 x 1.5	13	4.5	18	115	233	189	240	320	235	305

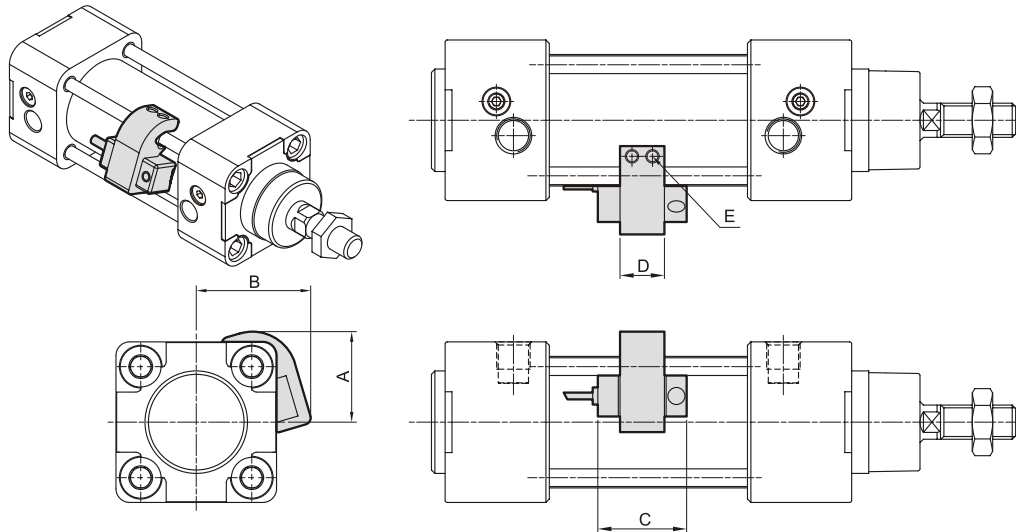

Code Tube I.D.	Sensor switch	Hold	A	B	C	D	E
MCQV2-32	RCA	HV1	26.5	33.5	26	13	M4×10L
MCQV2-40	RCA	HV1	29.5	36.5	26	13	M4×10L
MCQV2-50	RCA	HV2	37.5	41.5	26	13	M4×10L
MCQV2-63	RCA	HV2	42.5	46.5	26	13	M4×10L
MCQV2-80	RCA	HV3	49.5	54.5	26	13	M5×16L
MCQV2-100	RCA	HV3	57.5	62.5	26	13	M5×16L
MCQV-125	RCA	HV4	—	—	26	13	M4×10L
MCQV-160	RCA	PM16	—	—	26	12	M4×10L
MCQV-200	RCA	HA5V	—	—	26	15	M4×16L

■ Mounting accessories

LB

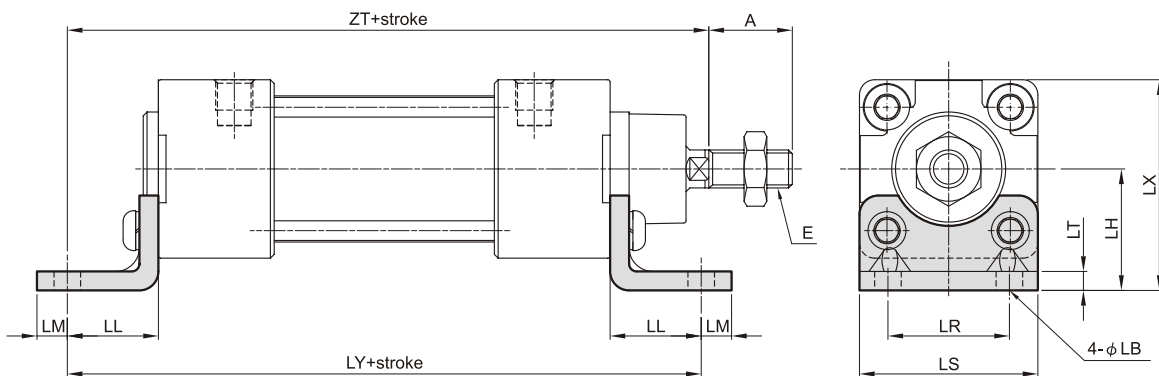

Code Tube I.D.	A	E	LB	LH	LL	LM	LR	LS	LT	LX	LY	ZT
32	22	M10×1.25	7	32	24	8	32	47	5	55.5	142	144
40	24	M12×1.25	9	36	28	10	36	53	5	63.2	161	163
50	32	M16×1.5	9	45	32	10	45	65	5	77.5	170	175
63	32	M16×1.5	9	50	32	10	50	75	5	89	185	190
80	40	M20×1.5	12	63	41	13	63	95	6	110.5	210	215
100	40	M20×1.5	14	71	41	13	75	115	6	128.5	220	230

FAC

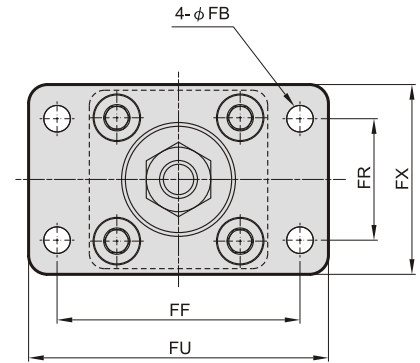
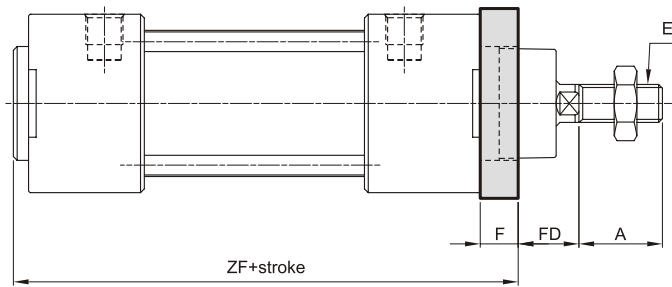

Code Tube I.D.	A	E	F	FB	FD	FF	FR	FU	FX	ZF
32	22	M10×1.25	10	7	16	64	32	79	50	108
40	24	M12×1.25	10	9	20	72	36	93	54	120
50	32	M16×1.5	12	9	25	90	45	112	67	123
63	32	M16×1.5	12	9	25	100	50	127	79	137
80	40	M20×1.5	16	12	30	126	63	158	98	148
100	40	M20×1.5	16	14	35	150	75	185	116	158

FBC

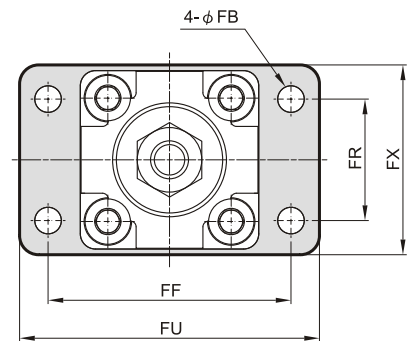
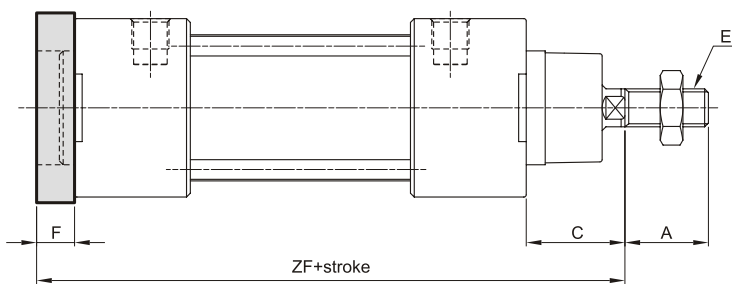

Code Tube I.D.	A	C	E	F	FB	FF	FR	FU	FX	ZF
32	22	26	M10×1.25	10	7	64	32	79	50	130
40	24	30	M12×1.25	10	9	72	36	93	54	145
50	32	37	M16×1.5	12	9	90	45	112	67	155
63	32	37	M16×1.5	12	9	100	50	127	79	170
80	40	46	M20×1.5	16	12	126	63	158	98	190
100	40	51	M20×1.5	16	14	150	75	185	116	205

CA

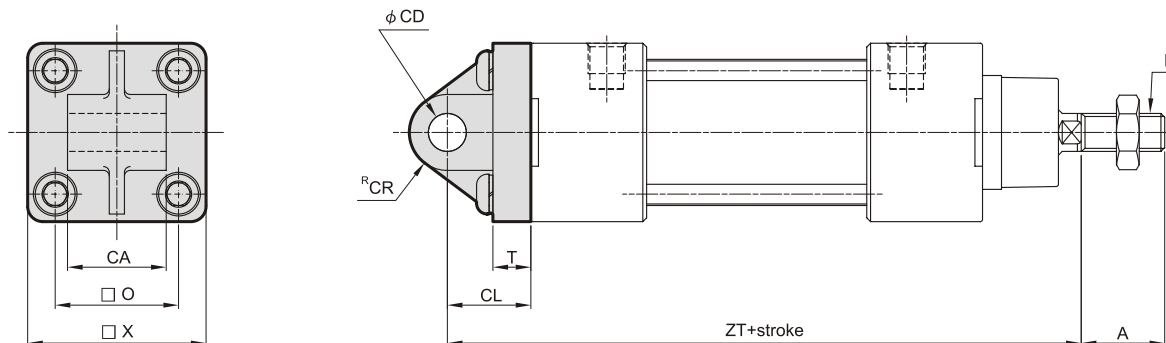

Code Tube I.D.	A	CA	CD	CL	CR	E	O	T	X	ZT
32	22	$26_{-0.3}^{-0.1}$	10^{H9}	22	10.5	M10 x 1.25	32.5	10	47	142
40	24	$28_{-0.3}^{-0.1}$	12^{H9}	25	12	M12 x 1.25	38	9	55	160
50	32	$32_{-0.3}^{-0.1}$	12^{H9}	27	14	M16 x 1.5	46.5	9	65	170
63	32	$40_{-0.3}^{-0.1}$	16^{H9}	32	18	M16 x 1.5	56.5	9	78	190
80	40	$50_{-0.3}^{-0.1}$	16^{H9}	36	17	M20 x 1.5	72	12	95	210
100	40	$60_{-0.3}^{-0.1}$	20^{H9}	41	21	M20 x 1.5	89	11	115	230

CB

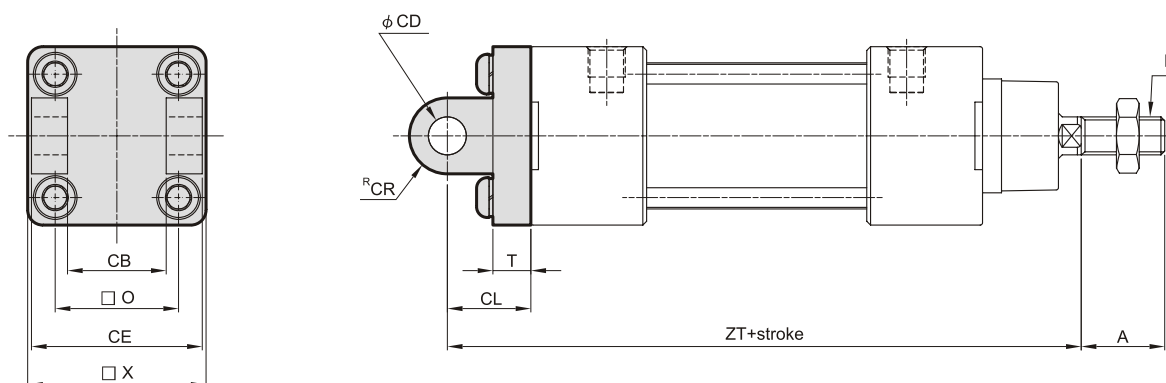

Code Tube I.D.	A	CB	CD	CE	CL	CR	E	O	T	X	ZT
32	22	$26_{+0.1}^{+0.3}$	10^{H9}	45	22	10.5	M10 x 1.25	32.5	10	47	142
40	24	$28_{+0.1}^{+0.3}$	12^{H9}	52	25	12	M12 x 1.25	38	9	55	160
50	32	$32_{+0.1}^{+0.3}$	12^{H9}	60	27	14	M16 x 1.5	46.5	9	65	170
63	32	$40_{+0.1}^{+0.3}$	16^{H9}	70	32	18	M16 x 1.5	56.5	9	78	190
80	40	$50_{+0.1}^{+0.3}$	16^{H9}	90	36	17	M20 x 1.5	72	12	95	210
100	40	$60_{+0.1}^{+0.3}$	20^{H9}	110	41	21	M20 x 1.5	89	11	115	230

CDB CB+Pin (Extra purchase)

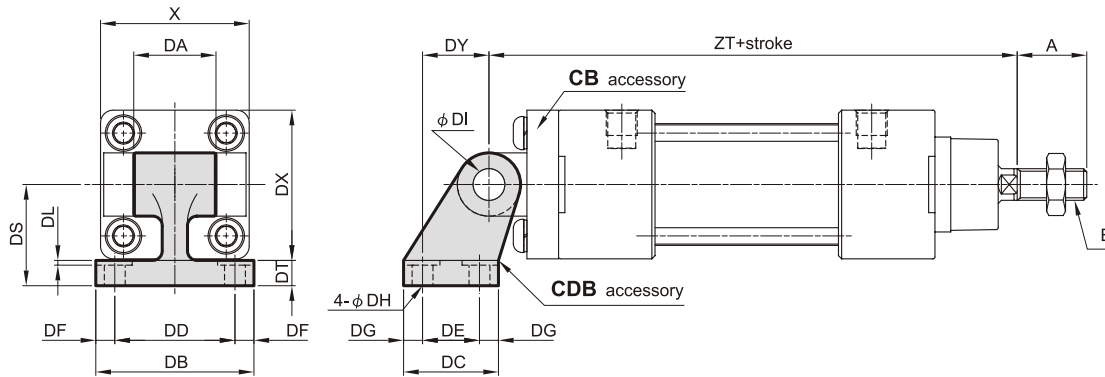

Code Tube I.D.	A	DA	DB	DC	DD	DE	DF	DG	DH	DI	DL	DS	DT	DX	DY	E	X	ZT
32	22	26	50	30	38	18	6	6	6.6	10	1.5	32	8	47.5	21	M10×1.25	47	142
40	24	28	53	34	41	22	6	6	6.6	12	1.5	36	10	52.5	24	M12×1.25	55	160
50	32	32	65	45	50	30	7.5	7.5	9	12	1.5	45	12	65.5	33	M16×1.5	65	170
63	32	40	67	50	52	35	7.5	7.5	9	16	1.5	50	12	75.5	37	M16×1.5	78	190
80	40	50	86	60	66	40	10	10	11	16	2.5	63	14	96.5	47	M20×1.5	95	210
100	40	60	96	70	76	50	10	10	11	20	2.5	71	15	113.5	55	M20×1.5	115	230

TC

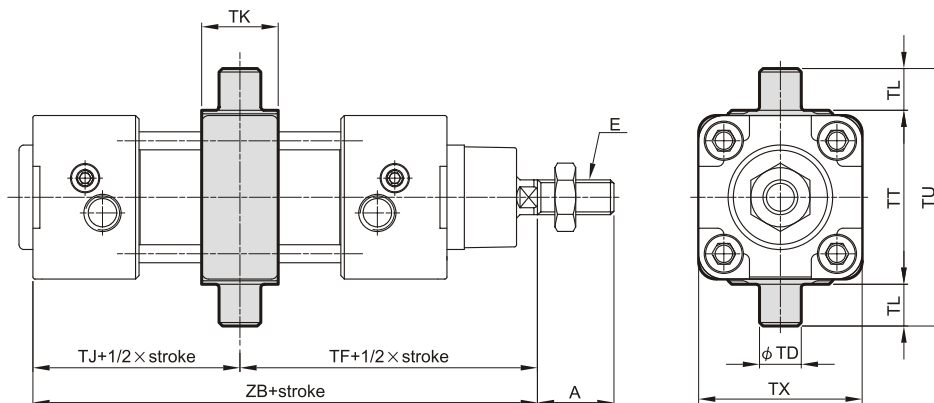

Code Tube I.D.	A	E	TD	TF	TJ	TK	TL	TT	TU	TX	ZB
32	22	M10×1.25	12 ^{SB}	73	47	22	12	50	74	47	120
40	24	M12×1.25	16 ^{SB}	82.5	52.5	22	16	63	95	53	135
50	32	M16×1.5	16 ^{SB}	90	53	22	16	75	107	66	143
63	32	M16×1.5	20 ^{SB}	97.5	60.5	28	20	90	130	80	158
80	40	M20×1.5	20 ^{SB}	110	64	34	20	110	150	106	174
100	40	M20×1.5	25 ^{SB}	120	69	40	25	132	182	126	189

TA

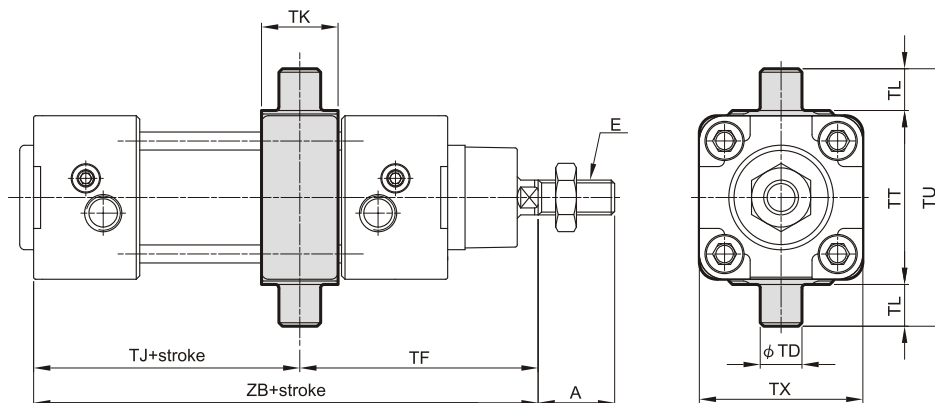

Code Tube I.D.	A	E	TD	TF	without magnet		magnet		TK	TL	TT	TU	TX
					TJ	ZB	TJ	ZB					
32	22	M10 × 1.25	12 ^{es}	68.5	51.5	120	81.5	150	22	12	50	74	47
40	24	M12 × 1.25	16 ^{es}	76	59	135	89	165	22	16	63	95	53
50	32	M16 × 1.5	16 ^{es}	80	63	143	93	173	22	16	75	107	66
63	32	M16 × 1.5	20 ^{es}	85	73	158	103	188	28	20	90	130	80
80	40	M20 × 1.5	20 ^{es}	99.5	74.5	174	114.5	214	34	20	110	150	106
100	40	M20 × 1.5	25 ^{es}	109	80	189	120	229	40	25	132	182	126

TB

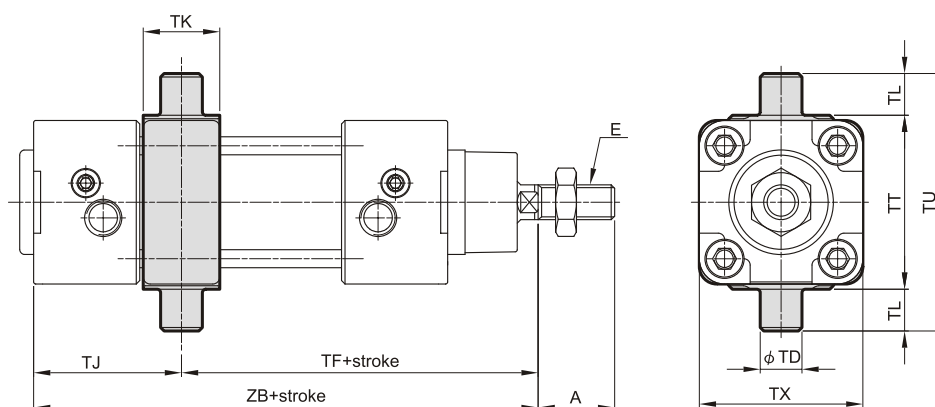

Code Tube I.D.	A	E	TD	without magnet		magnet		TJ	TK	TL	TT	TU	TX
				TF	ZB	TF	ZB						
32	22	M10 × 1.25	12 ^{es}	77.5	120	107.5	150	42.5	22	12	50	74	47
40	24	M12 × 1.25	16 ^{es}	89	135	119	165	46	22	16	63	95	53
50	32	M16 × 1.5	16 ^{es}	100	143	130	173	43	22	16	75	107	66
63	32	M16 × 1.5	20 ^{es}	110	158	140	188	48	28	20	90	130	80
80	40	M20 × 1.5	20 ^{es}	120.5	174	160.5	214	53.5	34	20	110	150	106
100	40	M20 × 1.5	25 ^{es}	131	189	171	229	58	40	25	132	182	126

11

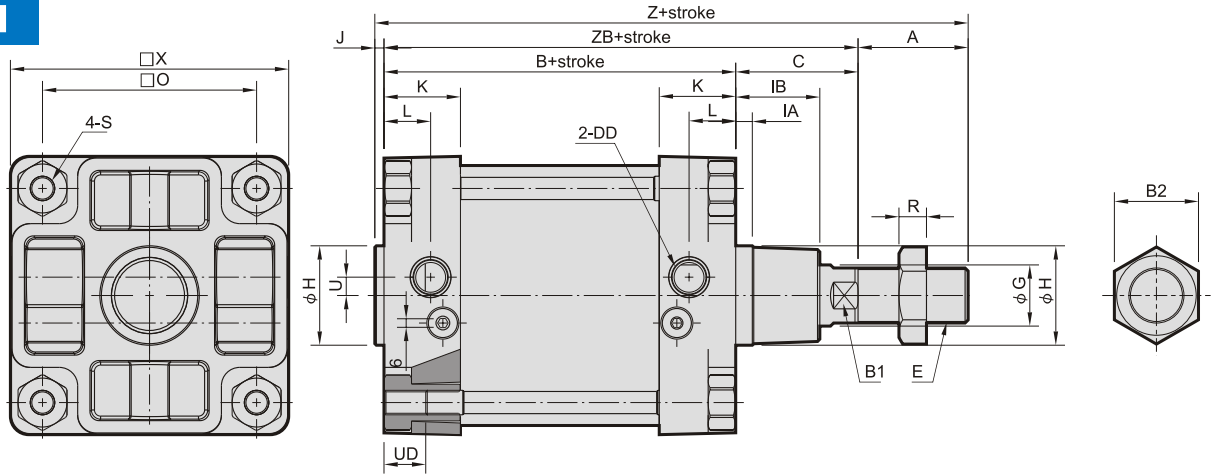

21

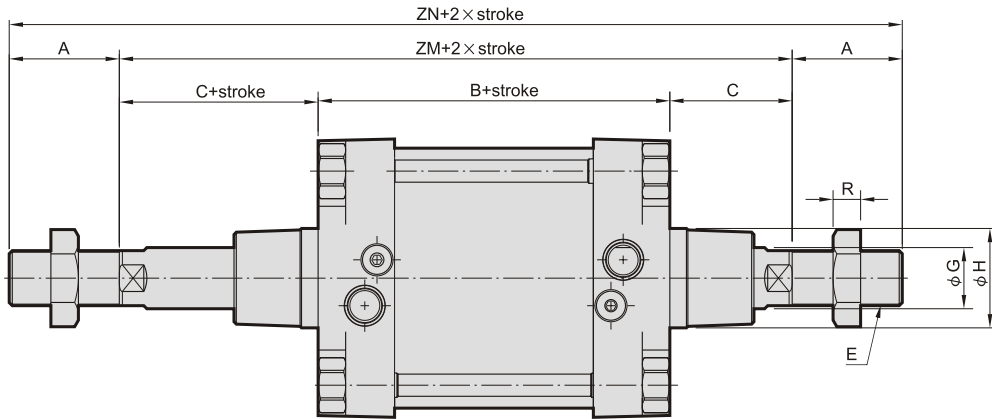

27

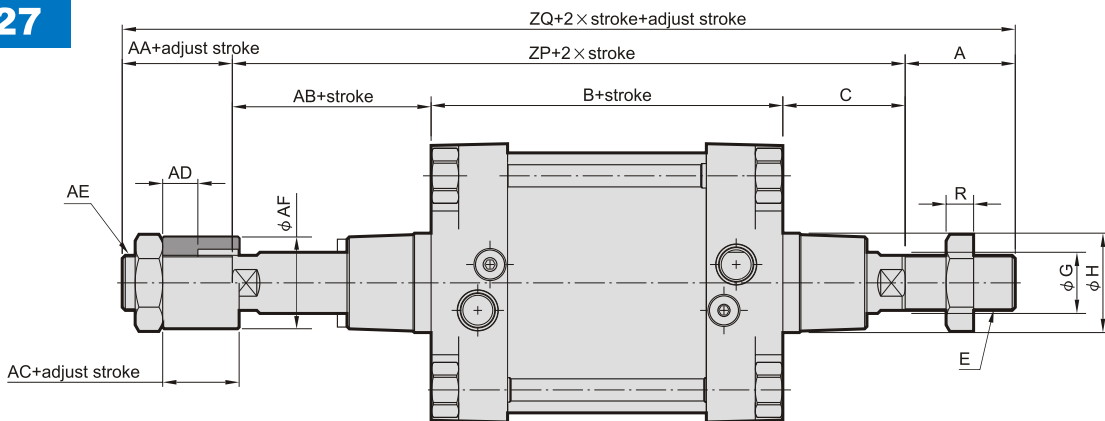

Code Tube I.D.	A	AA	AB	AC	AD	AE	AF	B	B1	B2	C	DD	E	G	H	IA	IB	J	K	L	O	R	S
125	54	38	55	30	18	M30 x 1.5	60	160	27	41	65	G1/2	M27 x P2.0	32	60 ^{e11}	10	40	6	40	25	110	13.5	M12 x 1.75
160	72	38	71	30	18	M30 x 1.5	60	180	36	55	80	G3/4	M36 x P2.0	40	65 ^{e11}	10	55	6	50	30.5	140	18	M16 x 2.0
200	72	40.5	94.5	42.5	20	M36 x 2	60	180	36	55	95	G3/4	M36 x P2.0	40	75 ^{e11}	15	55	6	56	36.5	175	18	M16 x 2.0

Code Tube I.D.	U	UD	X	Z	ZB	ZM	ZN	ZP	ZQ
125	11	22	140	285	225	290	398	280	372
160	12	27	182	338	260	340	484	331	441
200	12	28	220	353	275	370	514	369.5	482

LB

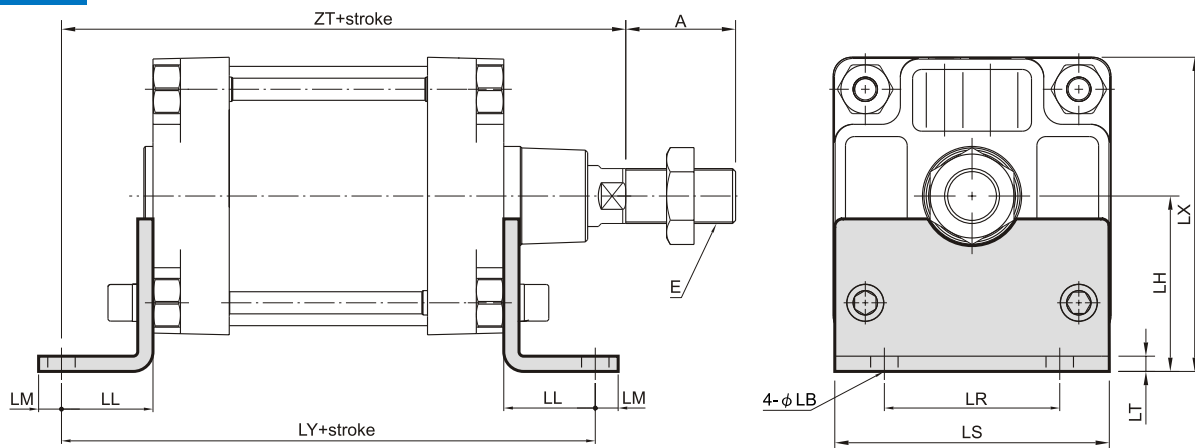

Code Tube I.D.	A	E	LB	LH	LL	LM	LR	LS	LT	LX	LY	ZT
125	54	M27×2.0	16	90	45	25	90	140	9	160	250	270
160	72	M36×2.0	18	115	60	15	115	180	10	206	300	320

FAC

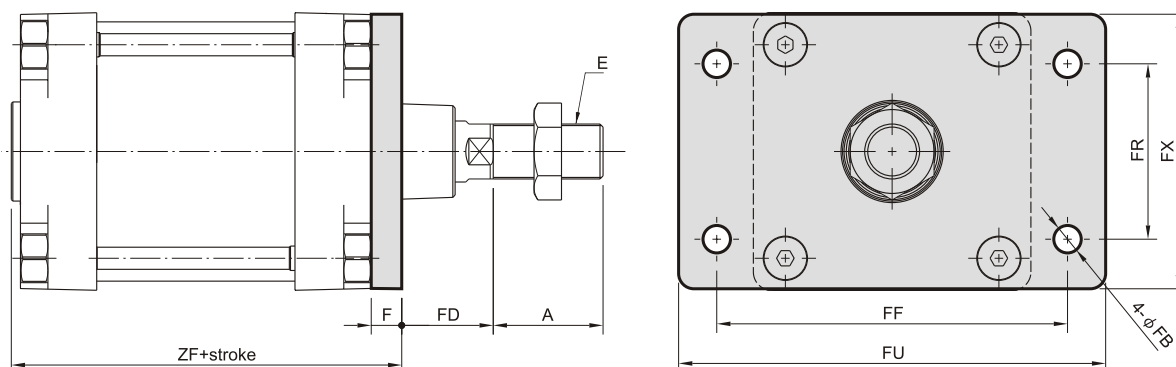

Code Tube I.D.	A	E	F	FB	FD	FF	FR	FU	FX	ZF
125	54	M27×2.0	20	16	45	180	90	211	140	186
160	72	M36×2.0	20	18	60	230	115	283	184	206

FBC

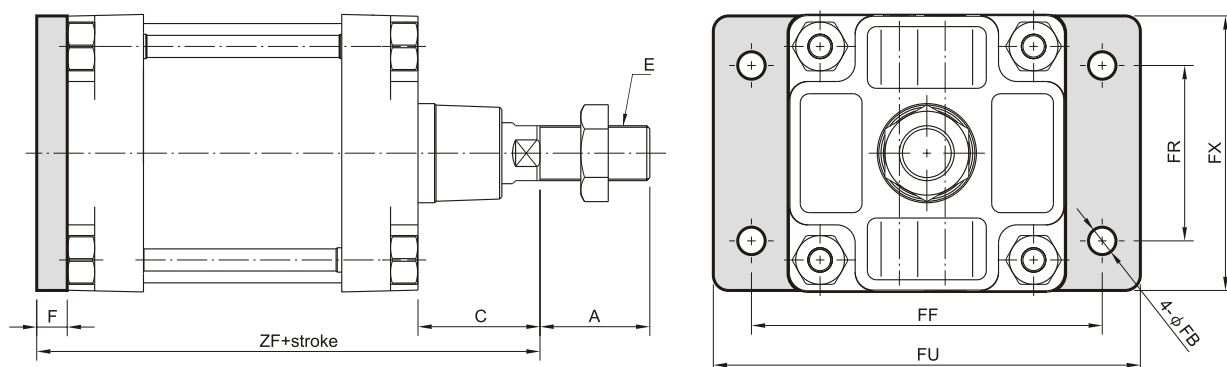

Code Tube I.D.	A	C	E	F	FB	FF	FR	FU	FX	ZF
125	54	65	M27×2.0	20	16	180	90	211	140	245
160	72	80	M36×2.0	20	18	230	115	283	184	280

CA

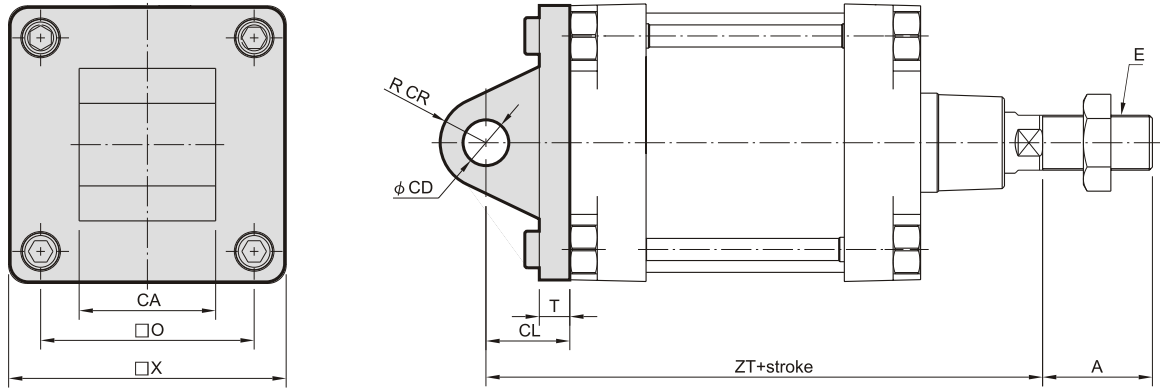

Code Tube I.D.	A	CA	CD	CL	CR	E	O	T	X	ZT
125	54	$70_{-0.3}^{-0.1}$	25^{H9}	50	25	M27 x 2.0	110	20	140	275
160	72	$90_{-1.2}^{-0.5}$	30^{H9}	55	30	M36 x 2.0	140	20	180	315

CB

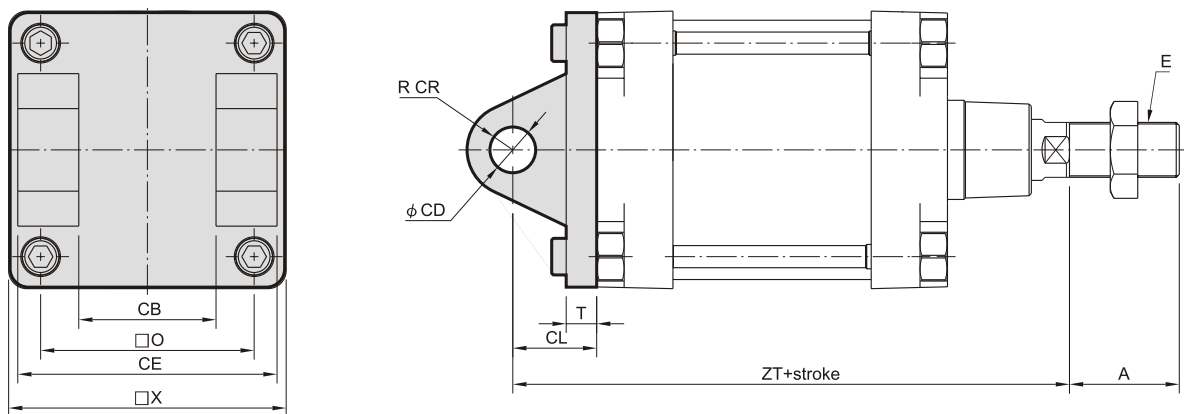

Code Tube I.D.	A	CB	CD	CE	CL	CR	E	O	T	X	ZT
125	54	70^{H14}	25^{H9}	$130_{-1.0}^{+0}$	50	25	M27 x 2.0	110	20	140	275
160	72	90^{H14}	30^{H9}	$170_{-0.7}^{+0}$	55	30	M36 x 2.0	140	20	180	315

TC

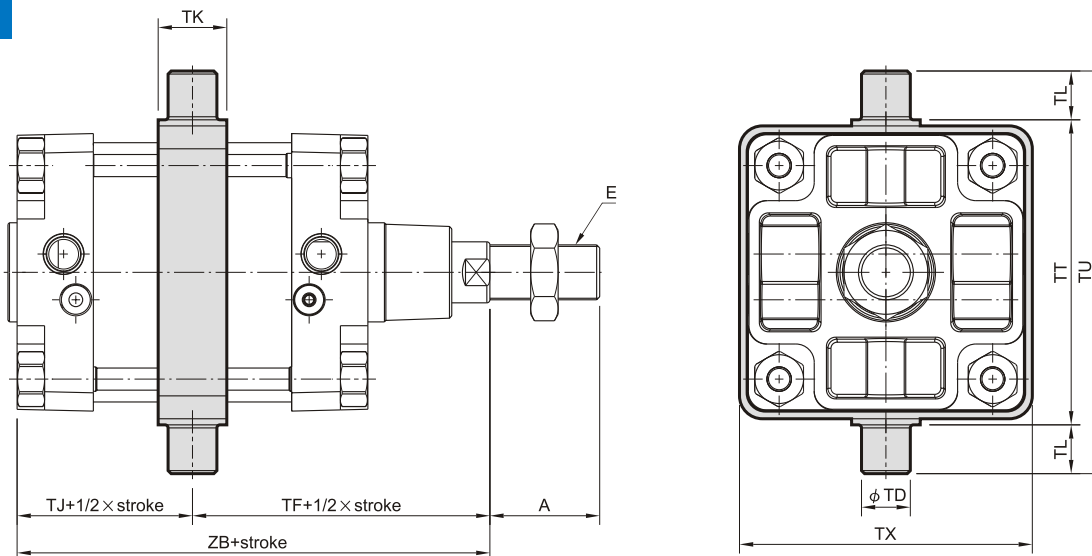

Code Tube I.D.	A	E	TD	TF	TJ	TK	TL	TT	TU	TX	ZB
125	54	M27 × 2.0	25 ^{ø9}	145	80	40	25	160	210	155	225
160	72	M36 × 2.0	32 ^{ø9}	170	90	45	32	200	264	192	260

TA

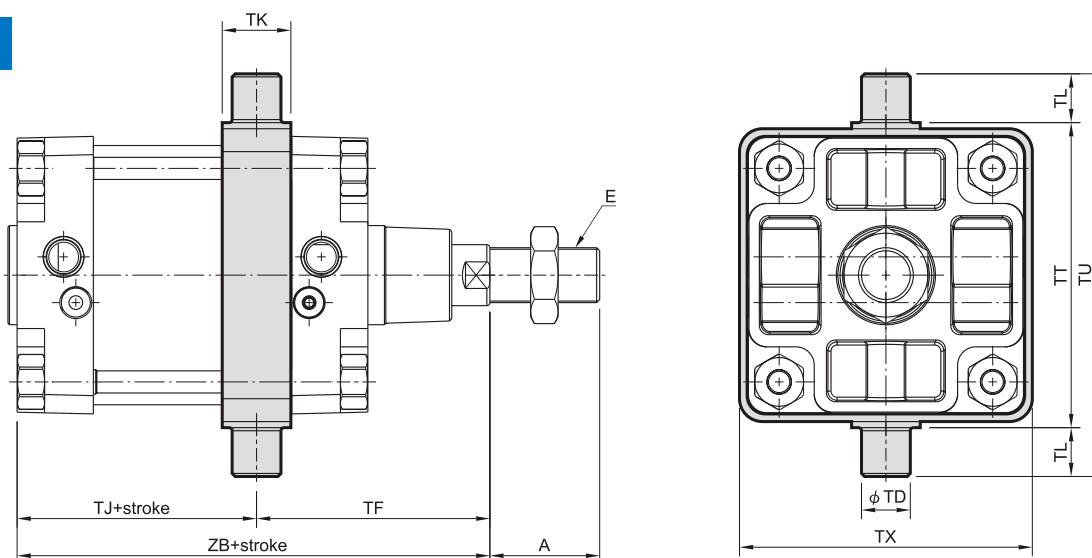

Code Tube I.D.	A	E	TD	TF	without magnet		magnet		TK	TL	TT	TX	TU
					TJ	ZB	TJ	ZB					
125	54	M27 × 2.0	25 ^{ø9}	125	100	225	146	271	40	25	160	155	210
160	72	M36 × 2.0	32 ^{ø9}	153	107	260	157	310	45	32	200	192	264

TB

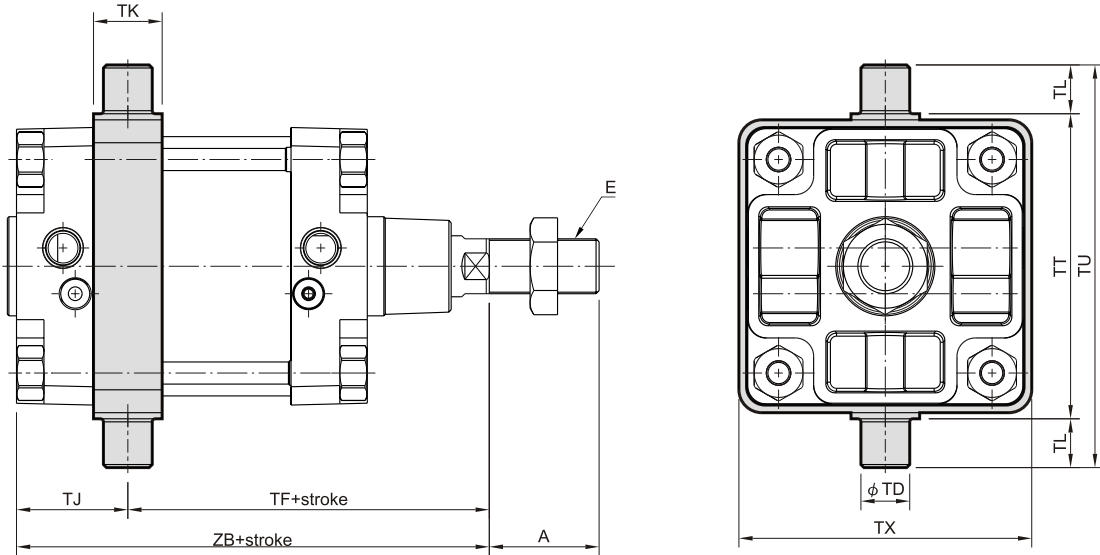

Code Tube I.D.	A	E	TD	without magnet		magnet		TJ	TK	TL	TT	TU	TX
				TF	ZB	TF	ZB						
125	54	M27×2.0	25 ^{±0.05}	165	225	211	271	60	40	25	160	210	155
160	72	M36×2.0	32 ^{±0.05}	187	260	237	310	73	45	32	200	264	192

Y connector

$\phi 32, \phi 40$

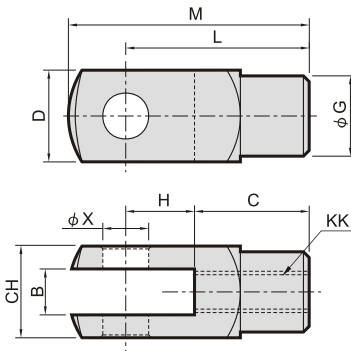

$\phi 50 \sim \phi 100$

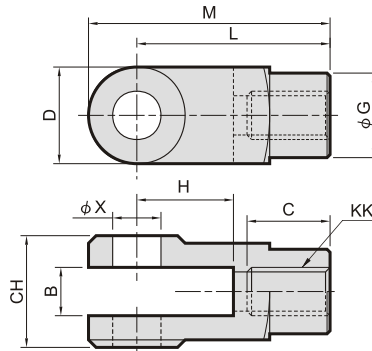

I connector

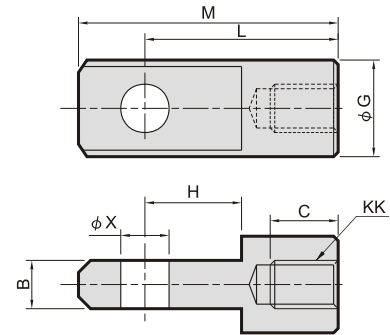

Code Tube I.D.	B		C		CH		D		G		H		L		KK		M		X ^{H9}
	Y	I	Y	I	Y	I	Y	I	Y	I	Y	I	Y	I	Y	I	Y	I	
32	10 ^{+0.05} _{+0.15}	10 ^{-0.1} _{-0.2}	20	17	19	/	19	/	$\phi 18$	$\phi 20$	20	15	40	40	M10 x 1.25	52	52	$\phi 10$ ^{+0.04} ₀	
40	12 ^{+0.05} _{+0.15}	12 ^{-0.1} _{-0.2}	24	21	24	/	24	/	$\phi 20$	$\phi 24$	24	18	48	48	M12 x 1.25	62	62	$\phi 12$ ^{+0.04} ₀	
50	16 ^{+0.3} _{+0.1}	16 ^{-0.1} _{-0.3}	28	23	32	/	32	/	$\phi 28$	$\phi 32$	32	32	64	64	M16 x 1.5	89	86	$\phi 16$ ^{+0.04} ₀	
63	16 ^{+0.3} _{+0.1}	16 ^{-0.1} _{-0.3}	28	23	32	/	32	/	$\phi 28$	$\phi 32$	32	32	64	64	M16 x 1.5	89	86	$\phi 16$ ^{+0.04} ₀	
80	20 ^{+0.3} _{+0.1}	20 ^{-0.1} _{-0.3}	33	30	45	/	40	/	$\phi 36$	$\phi 36$	40	40	80	80	M20 x 1.5	100	108	$\phi 20$ ^{+0.05} ₀	
100	20 ^{+0.3} _{+0.1}	20 ^{-0.1} _{-0.3}	33	30	45	/	40	/	$\phi 36$	$\phi 36$	40	40	80	80	M20 x 1.5	100	108	$\phi 20$ ^{+0.05} ₀	

Order example ※MCQV / MCQI are common accessories.

PIN – MCQV – 40 – Y – P

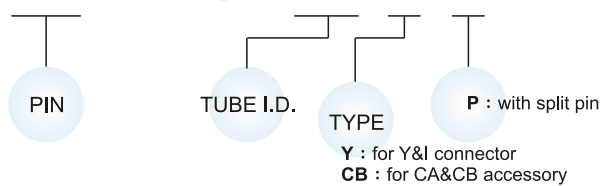

Pin

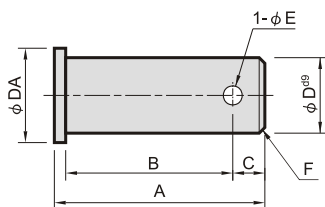

for Y.I connector

Code Tube I.D.	A	B	C	D ^{d9}	DA	E	F	Split pin
32	30	25	3.5	$\phi 10$ ^{-0.06} _{-0.09}	14	3.2	1	3.2 x 20L
40	37	30	5	$\phi 12$ ^{-0.06} _{-0.09}	16	3.2	1	3.2 x 20L
50 63	47	37	7	$\phi 16$ ^{-0.05} _{-0.09}	22	4	1	4 x 25L
80 100	62	50	8	$\phi 20$ ^{-0.06} _{-0.11}	30	5	1.5	5 x 35L

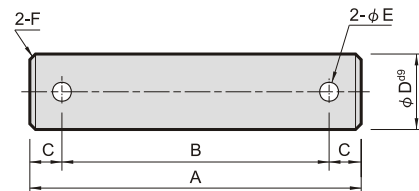

for CA.CB

Code Tube I.D.	A	B	C	D ^{d9}	E	F	Split pin
32	69	55	7	$\phi 10$ ^{-0.05} _{-0.09}	4	1.0	4 x 20L
40	76	62	7	$\phi 12$ ^{-0.05} _{-0.09}	4	1.0	4 x 20L
50	84	70	7	$\phi 12$ ^{-0.05} _{-0.09}	4	1.0	4 x 20L
63	94	80	7	$\phi 16$ ^{-0.05} _{-0.09}	4	1.0	4 x 30L
80	117	100	8.5	$\phi 16$ ^{-0.05} _{-0.09}	5	1.5	5 x 30L
100	137	120	8.5	$\phi 20$ ^{-0.05} _{-0.09}	5	1.5	5 x 35L

Y connector

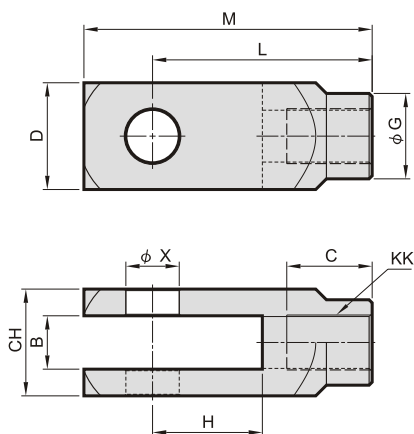

I connector

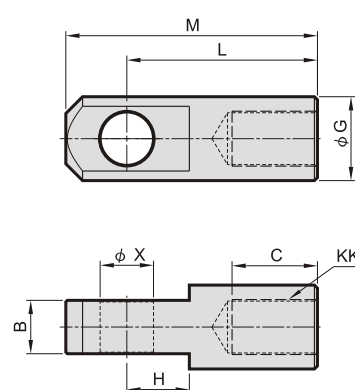

Code Tube I.D.	B		C		CH		D		G		H		KK		L		M		X ^{F7}	
	Y	I	Y	I	Y	I	Y	I	Y	I	Y	I	Y	I	Y	I	Y	I	Y	I
125	30 ^{+0.52} ₀	30 ^{-0.2} _{-0.3}	56	51	55	/	55	/	48	55	54	40	M27×2.0	110	110	148	145	30 ^{+0.52} ₀	30 ^{+0.04} _{+0.02}	
160	35 ^{+0.62} ₀	35 ^{-0.2} _{-0.3}	56	56	70	/	70	/	56	55	72	41	M36×2.0	144	125	189	165	35 ^{+0.05} _{+0.02}	35 ^{+0.05} _{+0.02}	
200	35 ^{+0.62} ₀	35 ^{-0.2} _{-0.3}	56	56	70	/	70	/	56	55	72	41	M36×2.0	144	125	189	165	35 ^{+0.05} _{+0.02}	35 ^{+0.05} _{+0.02}	

Pin

Order example

PIN—MCQV—125—Y—P

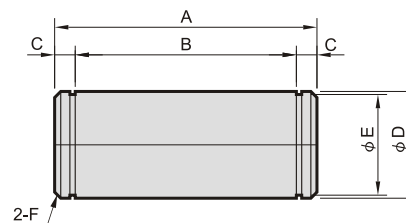
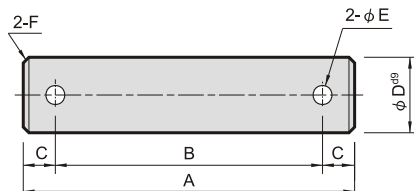
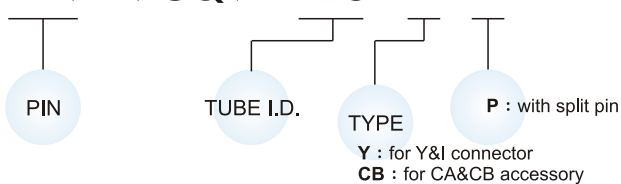

for $\phi 125$

Code Tube I.D.	A	B	C	D ^{d9}	E	F	Split pin
CB	157	140	8.5	$\phi 25_{-0.12}^{-0.07}$	5	1.5	5×36L
Y	81	64	8.5	$\phi 30_{-0.12}^{-0.07}$	6.3	1.5	6.3×40L

for $\phi 160, \phi 200$

Code Tube I.D.	A	B	C	D	E	F	Snap ring
CB	186	172	7	$30_{-0.09}^{+0.05}$	$28.6_{-0.21}^0$	2	STW—30
Y	86	72	7	$35_{-0.03}^{+0.07}$	$33_{-0.25}^0$	2	STW—35